

**OMNIS<sup>®</sup>**  
**AV Monitoring System**  
User Guide

# Table of Contents

## Chapters

<b>1 - System Components</b>	
1.1 Overview	1
1.2 Front / Rear Panels	2
<b>2 - Connections</b>	
2.1 Overview	3
<b>3 - Configuration</b>	
3.1 Overview	4
3.2 Systems	4
3.3 Devices	9
3.4 Displays	11
3.5 Settings	12
3.5.1 General - Tab	12
3.5.2 Security - Tab	17
3.5.3 Cloud - Tab	21
3.5.4 About - Tab	22
<b>4 - Monitoring</b>	
4.1 Overview	23
4.2 Health Map	23
4.3 Alerts	27
4.4 Log	28
4.5 Global Controls	30
<b>5 - Maintenance</b>	
5.1 General Maintenance	31

## Appendix

<b>A - OMNIS-ISAAC Setup</b>	
A.1 Overview	32
A.2 Requirements	32
A.3 Step-by-Step Procedure	32
<b>B - Technical Specifications</b>	
B.1 Main Specifications Table	36
B.2 OMNIS Processor - Shipping Info.	37
B.3 OMNIS Processor Dimensions	37
B.4 Network Ports	38

## Legal

Copyright © 2019-2026 Megapixel™.

The Megapixel™ logo is a trademark of H2VR HoldCo, Inc. Other trademarks and trade names may be used in this document to refer to products by other entities. Megapixel claims no proprietary interest in trademarks and trade names owned by others.

Information and specifications in this document are subject to change without notice. Megapixel assumes no responsibility or liability for any errors or inaccuracies that may appear in this manual.



## Contact

+1 818 884 5488

<http://megapixelvr.com>

## Safety Information

The symbols below are used throughout this manual to identify important safety information. Heed all warnings and safety information.

Symbol	Meaning
	Warning, Danger, or Caution Risk of injury to yourself or the product.
	Risk of Electrical Shock Risk of severe electrical shock.

## Warranty Information

Megapixel warrants the OMNIS®, a hardware product, against defects in materials and workmanship under normal use for a period of one (1) year from the date of retail purchase by the original end-user purchaser.

Megapixel does not warrant that the operation of the product will be uninterrupted or error free. Megapixel is not responsible for damage arising from failure to follow product or installation instructions.

## Installation Environment

The OMNIS is designed to be rack mounted in a central control room for fixed installations or flight cased for touring applications.

The unit has been qualified to operate in a dry environment within a temperature range of 0° - 60°C (32° - 140°F).

---

**NOTE:** Position the NUC with the heat sink's fins oriented vertically when possible. Keep the top surface unobstructed, avoiding stacking objects or bundling cables on or around the heat sink. Inspect the heat sink and vent slots regularly for dust, especially if operating in dusty environments. Avoid operating the NUC in confined spaces or near heat sources, as passive cooling relies entirely on ambient airflow and temperature differentials to move heat away.

---



**WARNING:** Below is a set of environmental conditions that must be met prior to installing Megapixel products. The installation and/or use of products in these environments not meeting these conditions may void all warranties.

- Installation locations must be free of moisture.
  - Installation locations must be dust free.
  - All heavy and dirty site work must be complete. This includes re-working or modifications to walls, ceiling and floor.
  - All construction materials and debris must be removed, area swept, vacuumed cleaned, and floor wet-mopped.
  - Building structure, roof, and walls are sealed and weather proofed. Roof successfully tested for leaks.
  - Outside drainage system and floor drains checked and tested to protect the equipment from flooding.
  - Floors sealed and cleaned.
  - All doors and windows installed and operational with weather seals.
  - All final wall preparation complete including all taping, joint compound and fire sealant. Walls to be primed and finish painted.
  - Overhead fire sprinkler or suppression system installed and pressure tested.
  - HVAC ducts blown free of debris. HVAC shall be operational/balanced and running 72 hours prior to equipment installation.
-

## FCC Statement

This equipment has been tested and found to comply with the limits for a class A digital device, pursuant to Part 15 of the FCC rules. These limits are designed to provide reasonable protection against harmful interference when the equipment is operated in a commercial environment.

This equipment generates, uses, and can radiate radio frequency energy. If the equipment is not installed and used as directed in the instruction manual, it may cause harmful interference to radio communications. It is the responsibility of the user to correct any interference.

## Carrying and Handling the Equipment

Before you handle the OMNIS, disconnect all cables and cords. Do not operate the OMNIS in areas with significant amounts of airborne dust or smoke, or near a humidifier. Tiny airborne particles can damage the equipment.

## Liquid Exposure

Keep the OMNIS away from all sources of liquid. Protect equipment from dampness, humidity, or wet weather, such as rain, snow, and fog.

## Power

Unplug the power cord (by pulling the connector, not the cord) and disconnect all other cables if any of the following conditions exist:

- The power cord or plug becomes frayed or otherwise damaged.
- Liquid has spilled onto the equipment.
- The equipment is exposed to rain or excess moisture or humidity.
- The equipment has been dropped, and has been damaged.
- You suspect that the equipment needs service or repair.
- You want to clean the case (use only the recommended procedure, described later in this document).



**IMPORTANT:** The only way to completely turn off power is to unplug the power cord.

**WARNING:** The AC cord has a three-wire grounding connector. This connector fits only a grounded AC outlet. If you are unable to insert the connector into an outlet because the outlet isn't grounded, contact a licensed electrician to replace the outlet with a properly grounded one. Do not defeat the purpose of the grounding pin.

## Repairing

The OMNIS does not have any user-serviceable parts. Do not attempt to replace or repair any components inside the equipment. If the equipment needs service, contact the company that provided or installed the equipment. If you open the equipment or install items, you risk damaging the equipment. Such damage isn't covered by the limited warranty on the equipment.

## Medical Device Interference

The OMNIS contains components that emit electromagnetic fields, which may interfere with pacemakers, defibrillators, or other medical devices. Maintain a safe distance of separation between your medical device and equipment. Consult your physician and medical device manufacturer for information specific to your medical device. If you suspect equipment is interfering with your pacemaker or any other medical device, stop using the equipment.

## Medical Conditions

If you have a medical condition that could be affected by using an OMNIS (i.e., seizures, blackouts), consult with your physician prior to using the OMNIS.

## High-Consequence Activities

The OMNIS is not intended to be used where failure could lead to death, injury, or severe environmental damage.

## Explosive Atmospheres

Using the OMNIS in any area with a potentially explosive atmosphere (i.e. where the air contains high levels of flammable chemicals, vapors, or particles (such as grain, dust, or metal powders), may be hazardous. Obey all signs and instructions.

## Using Connectors and Ports

Never force a connector into a port. When connecting a device, make sure the port is free of debris, that the connector matches the port, and that you have oriented the connector correctly in relation to the port.

## Storing the Equipment

If you are going to store the OMNIS for an extended period of time, keep it in a cool and dry location (ideally, 71° F or 22° C).

## Cleaning the Equipment

When cleaning the outside of the OMNIS and its components, first shut down the equipment, then unplug all cords and cables. Use canned air such as 'Turbo Blast' by ACL Staticide Inc. or a clean, soft, lint-free cloth to wipe the equipment exterior. Avoid getting moisture in any openings. Do not spray liquid on the equipment. Do not use sprays, solvents, abrasives, or cleaners.

## Changes

Megapixel provides this manual 'as is' without warranty of any kind, either expressed or implied, including but not limited to the implied warranties or merchantability and fitness for a particular purpose. Megapixel may make improvements and/or changes to the product(s) and/or the program(s) described in this publication at any time without notice.

This publication could contain technical inaccuracies or typographical errors. Changes are periodically made to the information in this publication; these changes are incorporated in new editions of this publication.

## Certifications



# 1 - System Components

The OMNIS is a specialized network appliance designed to monitor and manage large arrays of video walls. It aggregates up to 200 video processors into a single map view. The 'at a glance' real-time system status information can monitor a wide range of system status information including monitoring the temperature, link status, power supply status, and integrity of data flowing into and out of display devices. This assists with rapid diagnosis and in some cases resolving issues before a failure impacts the visual quality of the display.

The OMNIS provides four key services:

- System overview of all connected devices
- Notifications of events for connected devices
- Quick access to common tasks (Brightness, screen blanking)
- In depth device status details

## 1.1 Overview

The OMNIS is a small network appliance.

The OMNIS has three (3) Ethernet/LAN ports for connecting HELIOS, the display devices, tech laptops and wireless routers.

The system is configured remotely via a web app that can be hosted on a laptop or tablet running Chrome or Safari browsers.

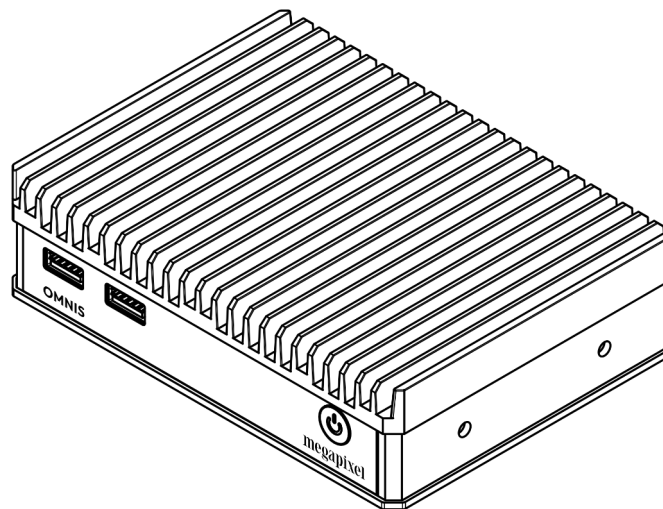

Figure 1: OMNIS unit

## 1.2 Front / Rear Panels

The front of the OMNIS has two USB 3.0 ports (A) and a pushbutton power switch (B).

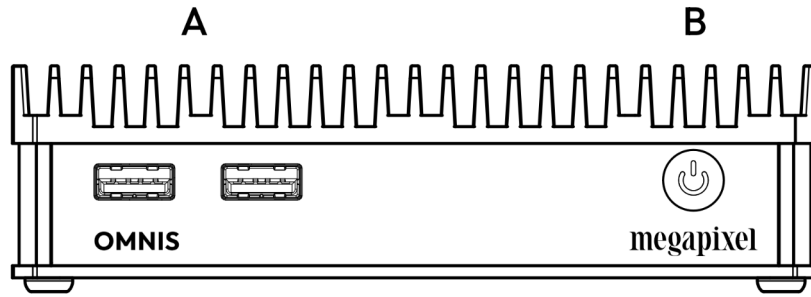

Figure 2: OMNIS front items

The rear of the OMNIS has three RJ-45 Gigabit Ethernet ports (C), a lockable DC power input (D), and a HDMI 2.0 port (E).

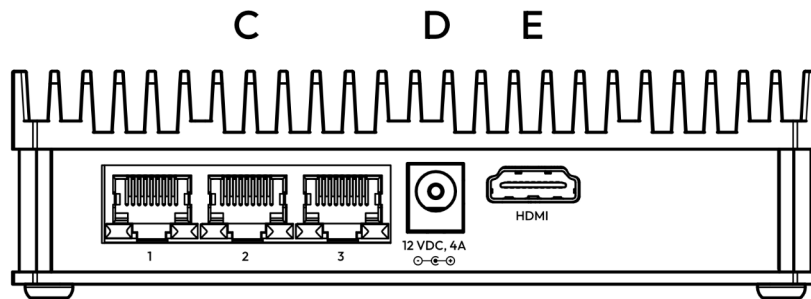

Figure 3: OMNIS Rear items

# 2 - Connections

## 2.1 Overview

The OMNIS system consists of the OMNIS processor, the system it is monitoring and the network connections in between.

## 2.2 Connections

**Power** - AC power is supplied to the OMNIS on a lockable DC input AC/DC adapter. There is a push button power switch on the front. When the push button is pressed, the system will begin to boot.

**Monitoring Ports** - Connect the LAN control port of a HELIOS display processor to the OMNIS Ethernet ports. OMNIS will automatically discover the system topology. Remember to assign all devices to the same LAN manually or use DHCP if available.

**User Interface** - The OMNIS system can be used with a wide variety of LED display products. The OMNIS must be configured to the system it monitors. Configuration of the OMNIS is accomplished with a web application. The web app runs on any remote host capable of running a modern web browser such as Chrome or Safari. In order to communicate with the OMNIS system, the web app host must be configured to be on the same LAN as the OMNIS.

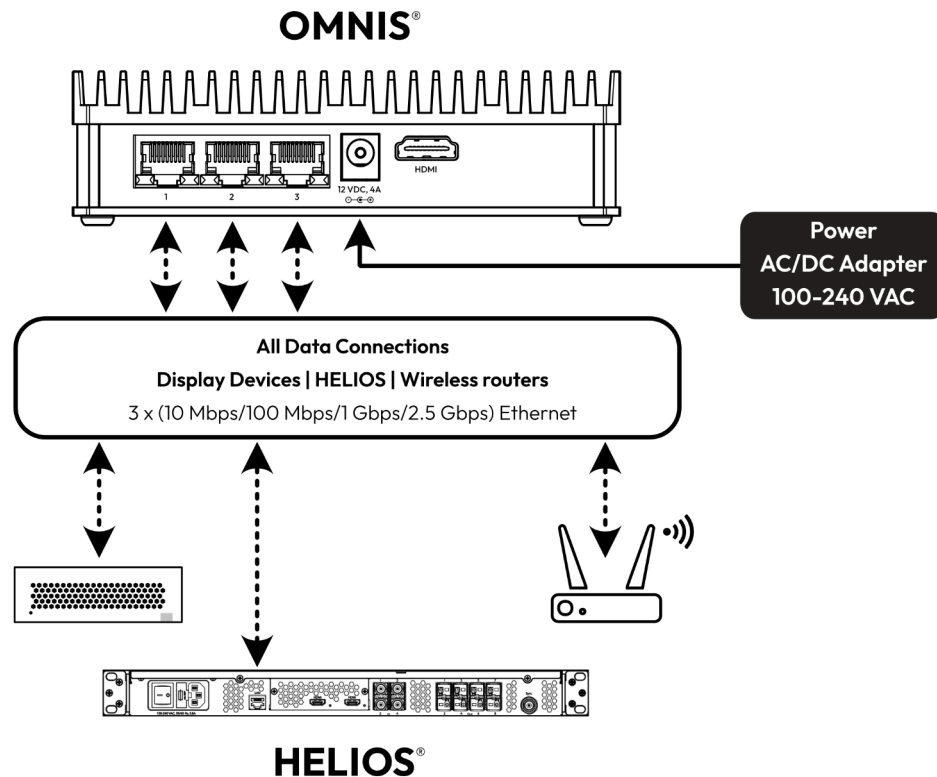

Figure 4: System connections

**NOTE:** To accommodate wireless-only devices like tablets, use a wireless router.

# 3 - Configuration

## 3.1 Overview

Prior to configuring the system, a majority of the components of the system should be physically connected. At minimum, the OMNIS should be connected to at least one monitoring target processor such as HELIOS. The web UI requires an IP network. Once the OMNIS finishes booting, its assigned IP address will appear on the HDMI monitor. Set the web UI client to this address range in order to communicate with the OMNIS. A factory fresh OMNIS will be set to DHCP. If the network has DHCP, the OMNIS will obtain an address automatically.



Figure 5: OMNIS monitor display

## 3.2 Systems

Enter the IP address of the target OMNIS into the search bar of Chrome or Safari on the tech laptop or tablet. The HELIOS reports the IP address of the unit on the HDMI display. The first step to configuring an OMNIS processor is to navigate to the **Systems** pane and press the **Add System** button. Systems are containers for one or more devices. The example below shows a new OMNIS with no systems added.

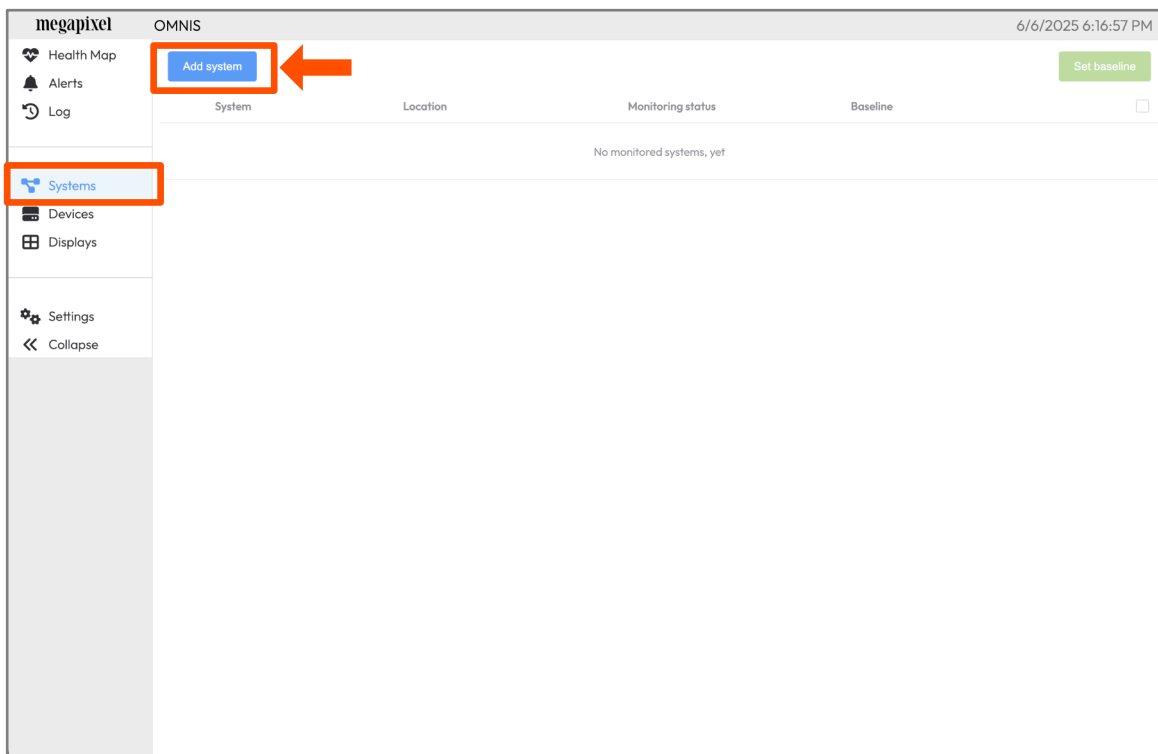
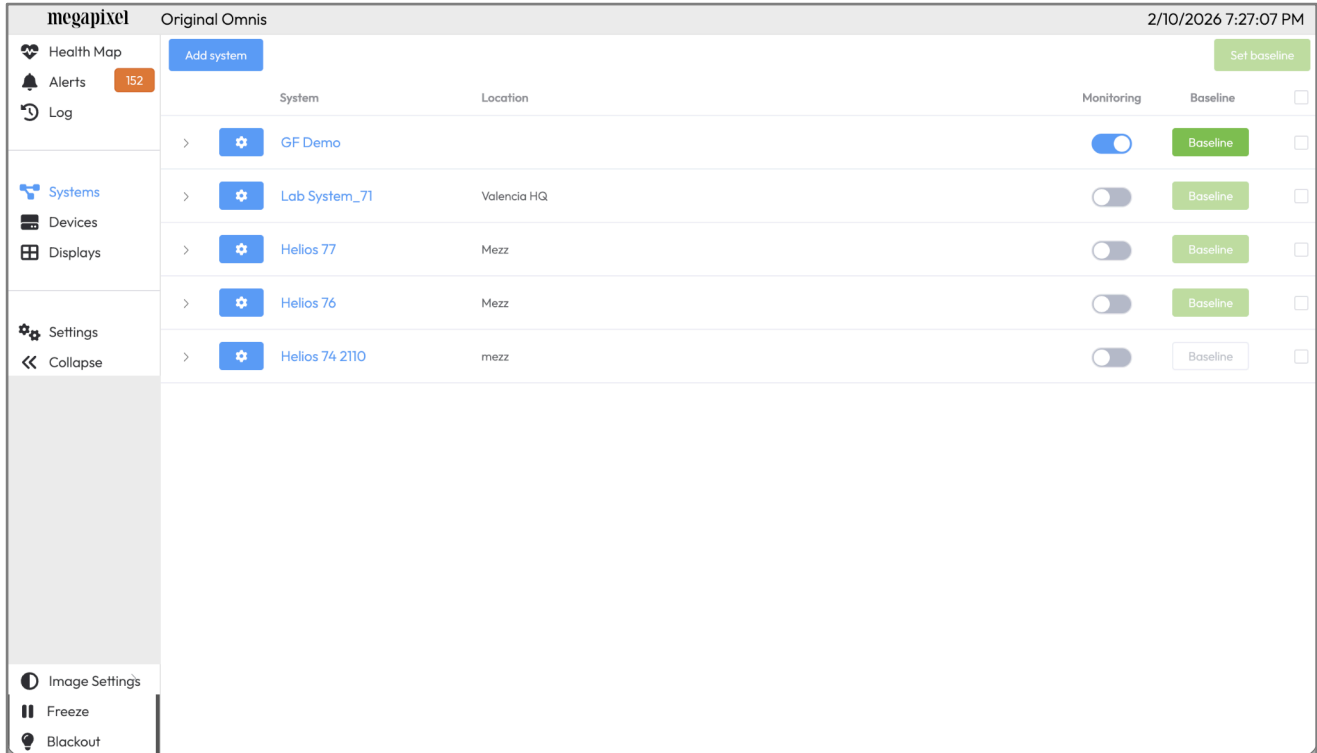

Figure 6: Add System

## 3.2 Systems (continued)

Once systems have been added, they are listed on the **Systems** pane. Steps to adding systems are detailed on the following pages.



The screenshot shows the 'megapixel Original Omnis' interface. The top right corner displays the date and time: '2/10/2026 7:27:07 PM'. On the left, there is a navigation sidebar with options: Health Map, Alerts (152), Log, Systems (selected), Devices, Displays, Settings, and Collapse. Below the sidebar are icons for Image Settings, Freeze, and Blackout. The main content area features an 'Add system' button and a 'Set baseline' button. A table lists the following systems:

System	Location	Monitoring	Baseline	
> GF Demo		<input checked="" type="checkbox"/>	Baseline	<input type="checkbox"/>
> Lab System_71	Valencia HQ	<input type="checkbox"/>	Baseline	<input type="checkbox"/>
> Helios 77	Mezz	<input type="checkbox"/>	Baseline	<input type="checkbox"/>
> Helios 76	Mezz	<input type="checkbox"/>	Baseline	<input type="checkbox"/>
> Helios 74 2110	mezz	<input type="checkbox"/>	Baseline	<input type="checkbox"/>

**Figure 7:** Systems listed

## 3.2 Systems (continued)

1. Fill in the system details then press **Add** to create a system.

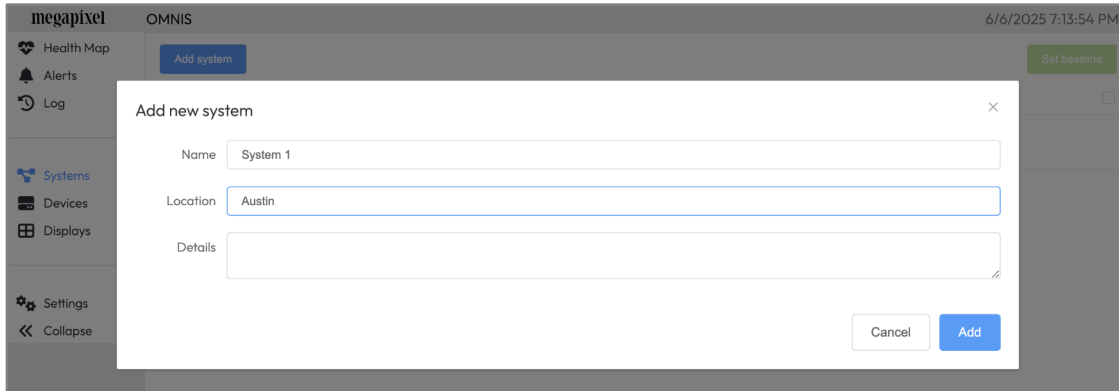

The screenshot shows the 'Add new system' dialog box in the megapixel OMNIS interface. The dialog has a title bar with 'Add new system' and a close button. It contains three input fields: 'Name' with the value 'System 1', 'Location' with the value 'Austin', and 'Details' which is empty. At the bottom right, there are 'Cancel' and 'Add' buttons. The background shows the main interface with a sidebar containing 'Health Map', 'Alerts', 'Log', 'Systems', 'Devices', 'Displays', 'Settings', and 'Collapse'.

**Figure 8:** Add new system form

2. Press the **Add device** button to add a device such as a HELIOS to the system that was just created.

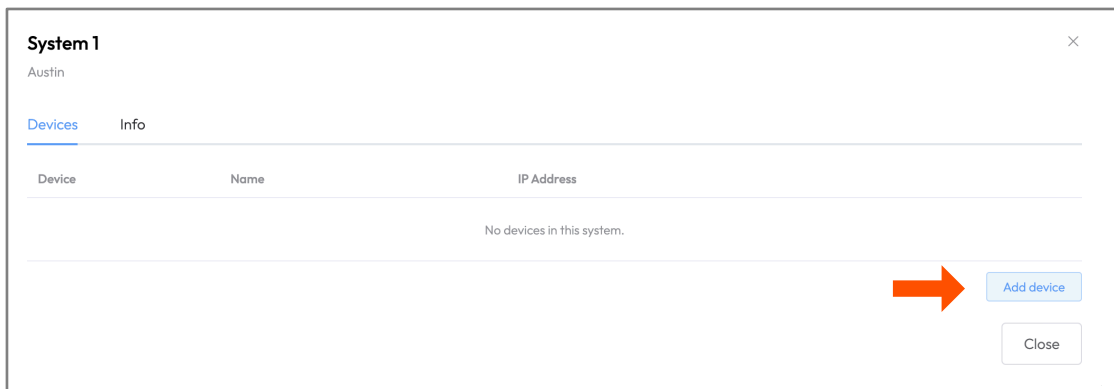

The screenshot shows the 'System 1' view in the megapixel OMNIS interface. The view has a title bar with 'System 1' and a close button. Below the title bar, it shows 'Austin' and two tabs: 'Devices' (selected) and 'Info'. Below the tabs, there is a table with columns 'Device', 'Name', and 'IP Address'. The table is empty and contains the text 'No devices in this system.' At the bottom right, there are 'Add device' and 'Close' buttons. An orange arrow points to the 'Add device' button.

**Figure 9:** Add device button

3. Once the device details have been provided to the OMNIS, press the **Add** button.

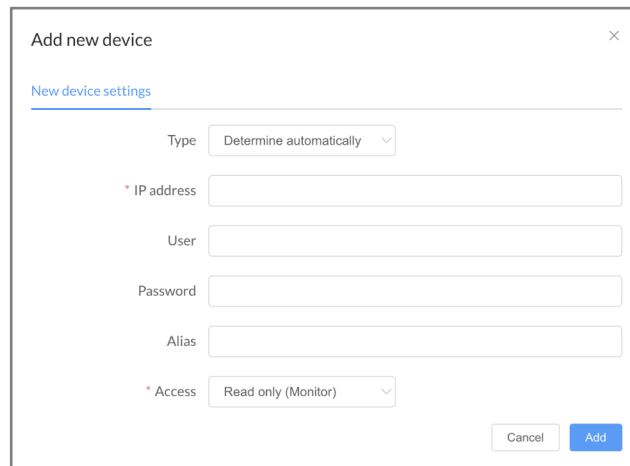

The screenshot shows the 'Add new device' dialog box in the megapixel OMNIS interface. The dialog has a title bar with 'Add new device' and a close button. Below the title bar, there is a section titled 'New device settings'. It contains several input fields and dropdown menus: 'Type' (Determine automatically), '\* IP address', 'User', 'Password', 'Alias', and '\* Access' (Read only (Monitor)). At the bottom right, there are 'Cancel' and 'Add' buttons.

**Figure 10:** Add device form

## 3.2 Systems (continued)

The device will now appear under the disclosure triangle of the system it is part of.

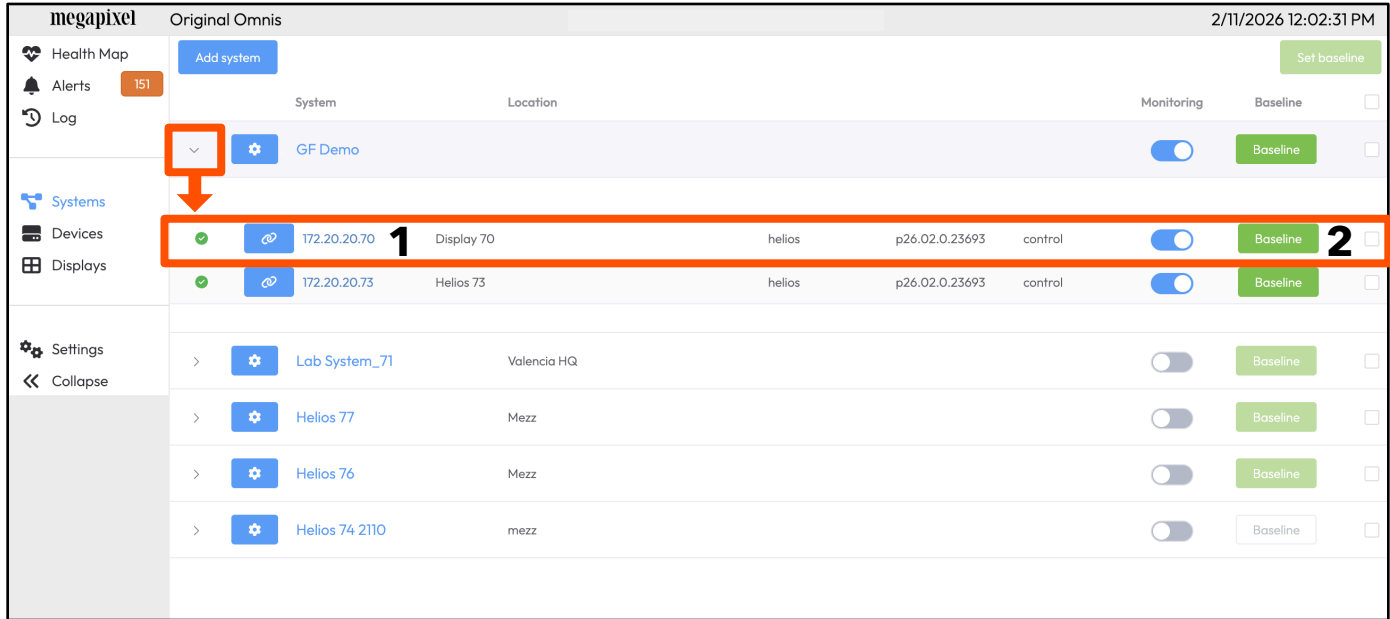

Figure 11: Device added

1. **URL** - Visit the UI of a HELIOS by clicking on the URL.
2. **Baseline** - In the OMNIS system, a baseline is a comprehensive set of data points that OMNIS stores to create a snapshot of the system. It serves as a fixed point of comparison for detecting changes or deviations.

Creating a baseline:

- Configure the system and ensure it is fully operational with no alerts or issues.
- Press the Baseline button to record the current state.

Once the baseline is set, OMNIS will continuously monitor for deviations and issue a deviation alert if it detects a change from the baseline.

Example:

A panel moving to a new location on the raster map is normally not alert-worthy—unless it happens after the system has been baselined.

How it works:

- After baselining, OMNIS establishes fixed reference points.
- If parameters change (e.g., map position), the system will trigger deviation alerts for all affected parameters.
- A single event may generate multiple alerts if it affects more than one parameter.

For more details on deviation alerts, see the [Alerts](#) section in Chapter 4.

## 3.2 Systems (continued)

**NOTE:** Novastar processors have a known issue when monitored by OMNIS while simultaneously being controlled from their proprietary software. The Novastar interface can be quite unresponsive and unreliable. This is due to the fact that the Nova processor can only support a single connection at a time. OMNIS must be temporarily disconnected to eliminate the erratic behavior. To do this, edit the Novastar system and change the access to **Disabled**.

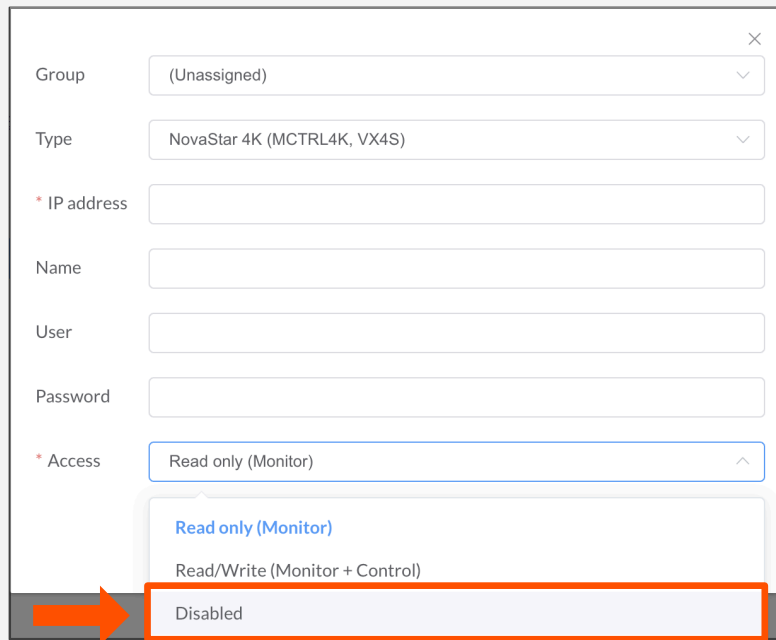

The image shows a configuration form for a Novastar system. The form includes the following fields:

- Group: (Unassigned)
- Type: NovaStar 4K (MCTRL4K, VX4S)
- \* IP address: [Empty text box]
- Name: [Empty text box]
- User: [Empty text box]
- Password: [Empty text box]
- \* Access: Read only (Monitor)

The 'Access' dropdown menu is open, showing three options:

- Read only (Monitor)
- Read/Write (Monitor + Control)
- Disabled

An orange arrow points to the 'Disabled' option, which is also highlighted with an orange border.

### 3.3 Devices

The devices pane lists **All** connected devices. Devices are grouped by type. **Processors** are listed first. **Tiles** have their own tab next to the **All** tab. Expand the drop down to view the input details.

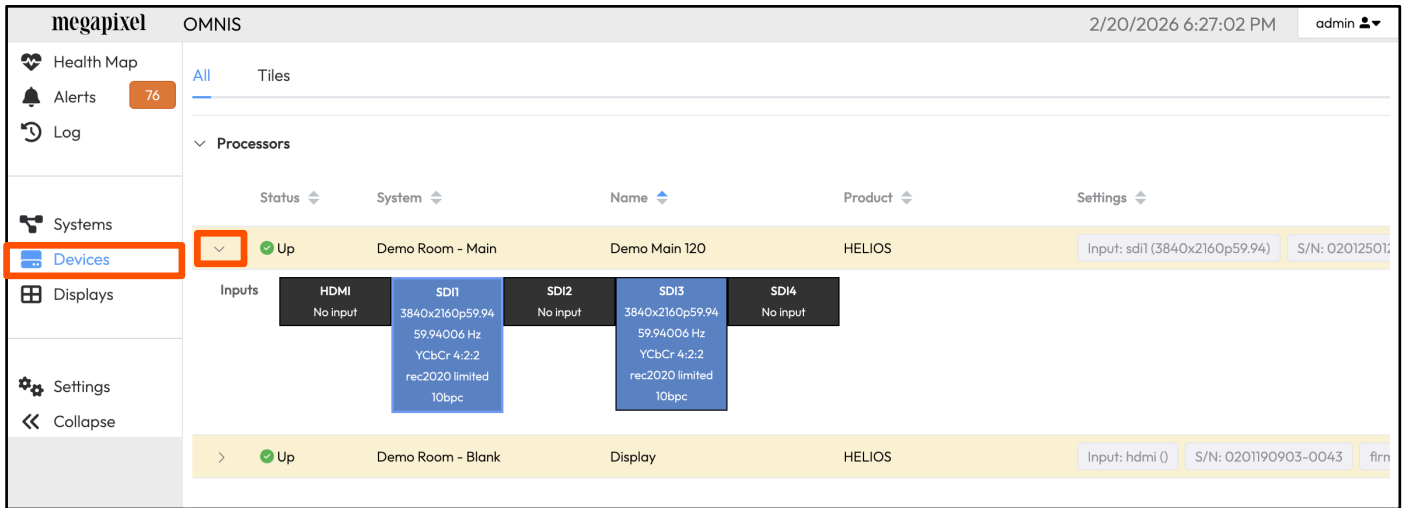

Figure 12: Devices

**Network switches** section lists all network switches in a system. Expand each to view switch port information. This view gives a dashboard view of detailed information for all the ports in a system. Ports are laid out in numerical order, with each 'cell' representing one port on the switch.

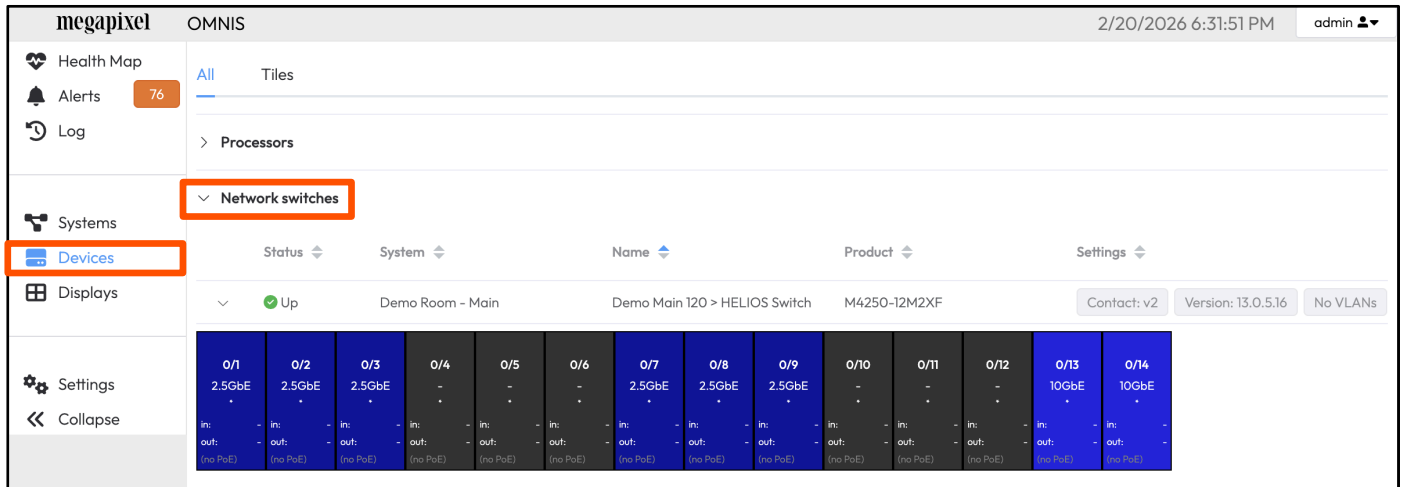

Figure 13: Network switches

### 3.3 Devices (Continued)

1. **Port number** - of the connected HELIOS. HELIOS units have eight (8) possible ports. The HELIOS name is automatically set by HELIOS on connecting to the switch to identify the main display data input to the switch.
2. **Port address** - standard networking equipment port addressing for NETGEAR switches. Unit number / Slot number / Port number. Smaller switches that do not have modular slots will not have the middle slot number. If there are only two numbers here they stand for Unit / Port.
3. **Link speed** - Indicates the data rate at which the system is connected through this port.
4. **VLAN label** - Short names are preferable and should be named according to the function in the system. The [1] default label is reserved for inbound HELIOS data. Tile ports will be labeled with their VLAN ID and Tile Data port number.
5. **In / Out** bound data as percent of port link speed.

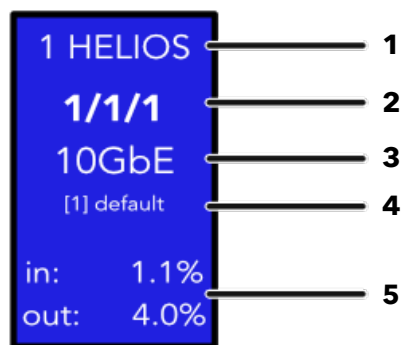

Figure 14: Network switch port status legend

## 3.4 Displays

The **Displays** pane contains the controls for the visible aspects of a display such as which input is in use, test patterns, blackout etc. Select the system name from the list to begin controlling a display.

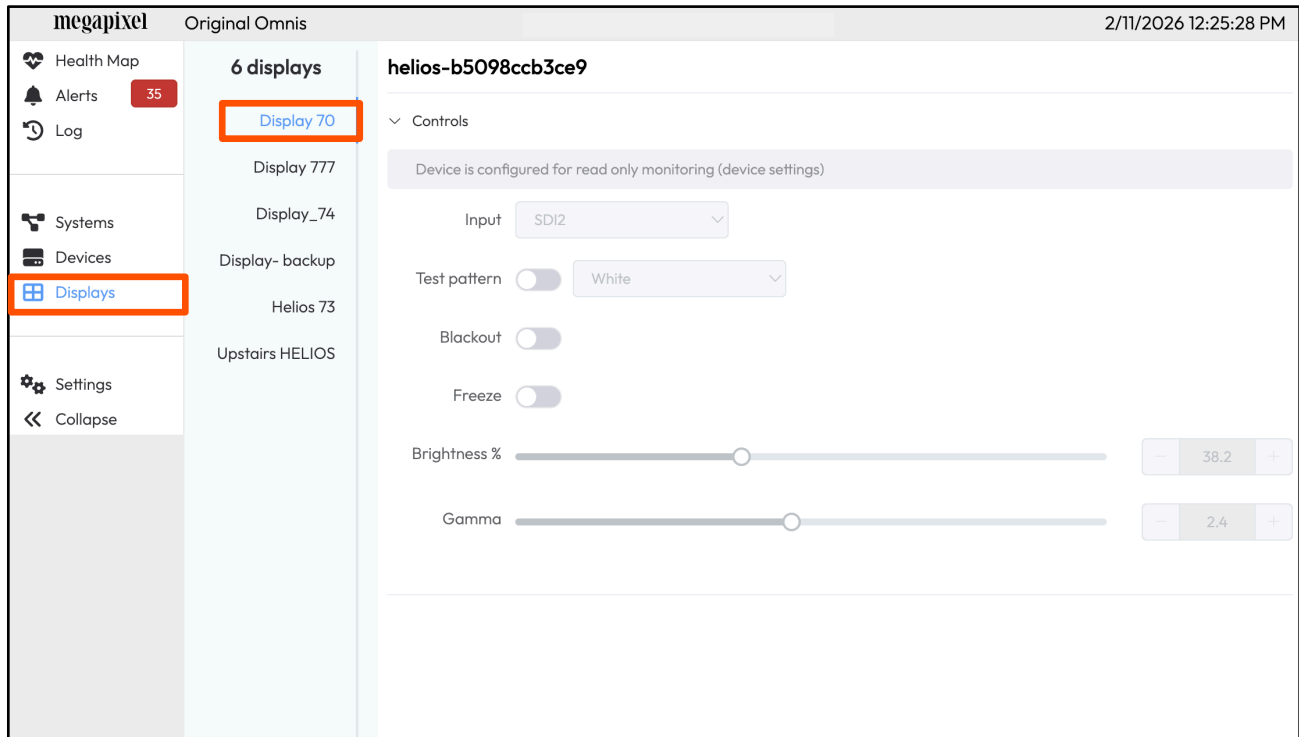

Figure 15: Displays

**NOTE:** To prevent unwanted changes being made to a display the Display controls are usually kept disabled. Enable them under **Settings > General > General > Display controls**. See the next section.

## 3.5 Settings

The **Settings** pane contains four (4) tabs: **General**, **Security**, **Cloud**, and **About**.

### 3.5.1 General - Tab

The **General** accordion has a field for naming. Use the **Display Controls** toggle to enable the display controls in the **Displays** pane (previous section).

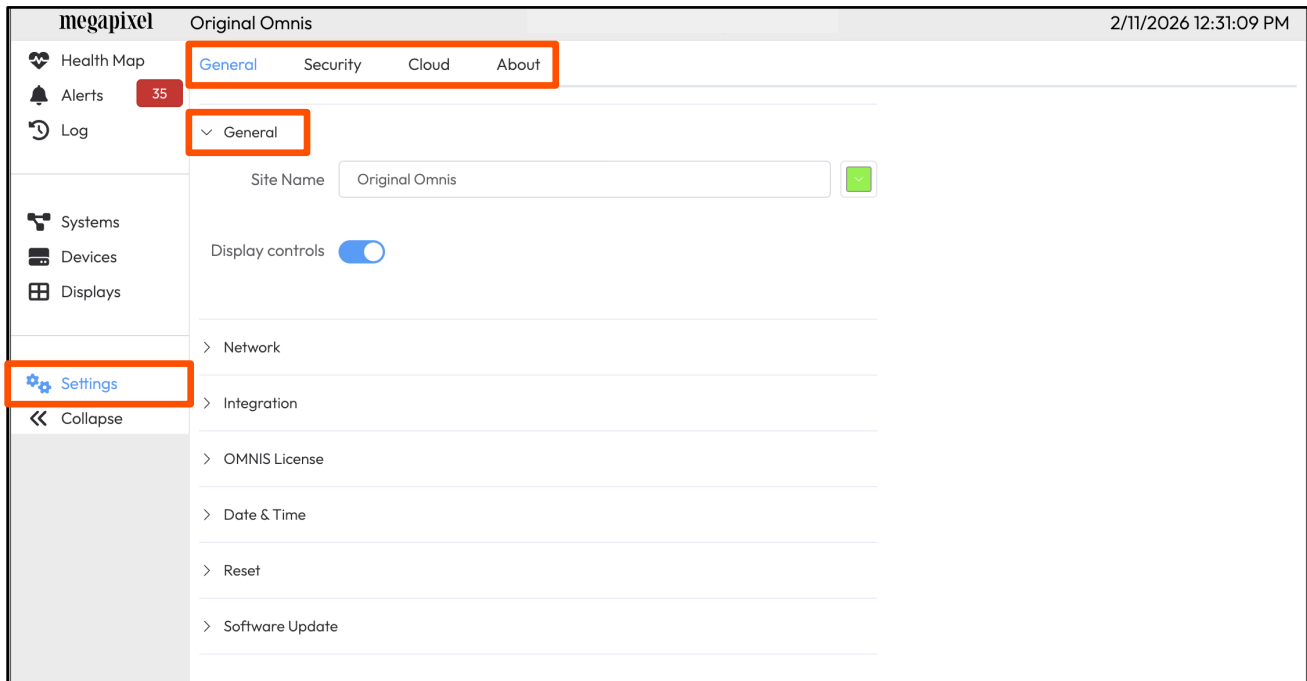

Figure 16: Settings

### 3.5.1 General - Tab (Continued)

The **Network** accordion contains a **Discoverable** toggle that enables protocols to advertise OMNIS on a network. Use **DHCP** to automatically connect to a router. With **DHCP** disabled, the IP information needs to be manually entered. In security conscious environments, OMNIS can be set to redirect to a HTTPS URL.

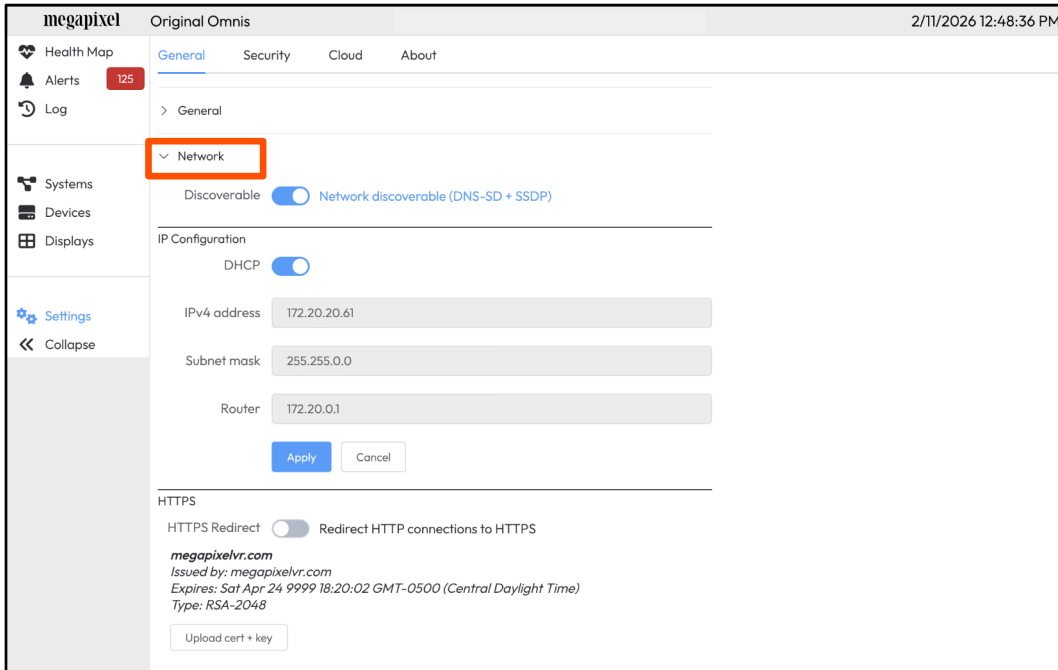

Figure 17: Network settings

The **Integration** accordion contains a toggle to enable a connection to the ISAAC system. Enter the IP address of the ISAAC unit and a name for the OMNIS unit. On the ISAAC side, it also needs to be configured to receive the OMNIS connection.

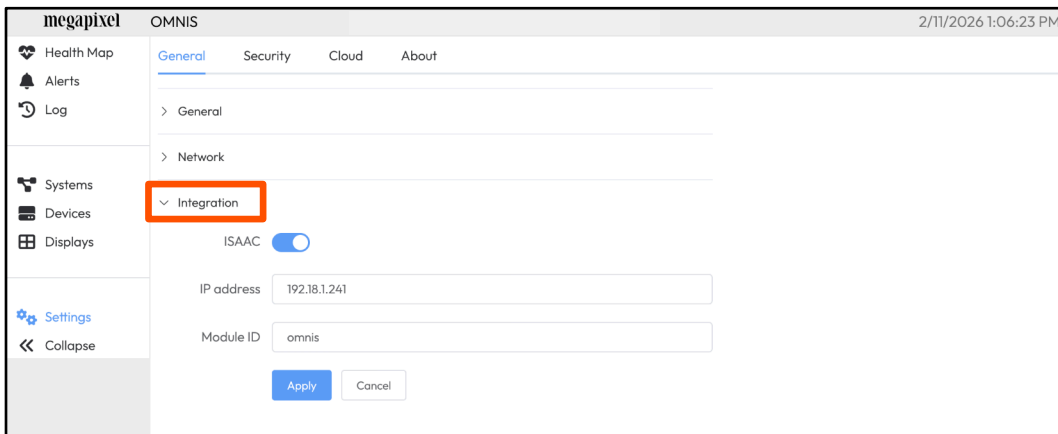

Figure 18: Integration

### 3.5.1 General - Tab (Continued)

**OMNIS License** accordion contains a unique **System ID** that is required when obtaining a license. This is also the location to upload a license file. License files can be obtained directly from Megapixel. Please contact your Megapixel representative for more information.

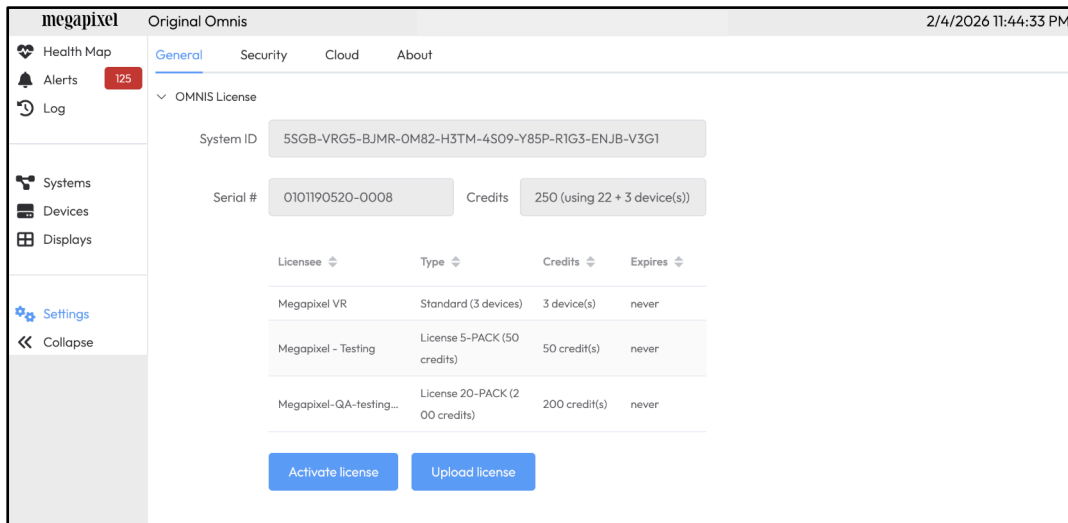

Figure 19: OMNIS License

**Date & Time** accordion. In most cases, OMNIS automatically determines the time from an NTP server. In the event OMNIS is unable to retrieve the time from an NTP server, it may be manually set here. Press the clock icon to open the Date and Time picker and set the desired time. Clicking the small blue **Now** button [Now](#) in the Date and Time picker will adjust the time to the web client computer's current clock. Press **Set** to apply this time to OMNIS.

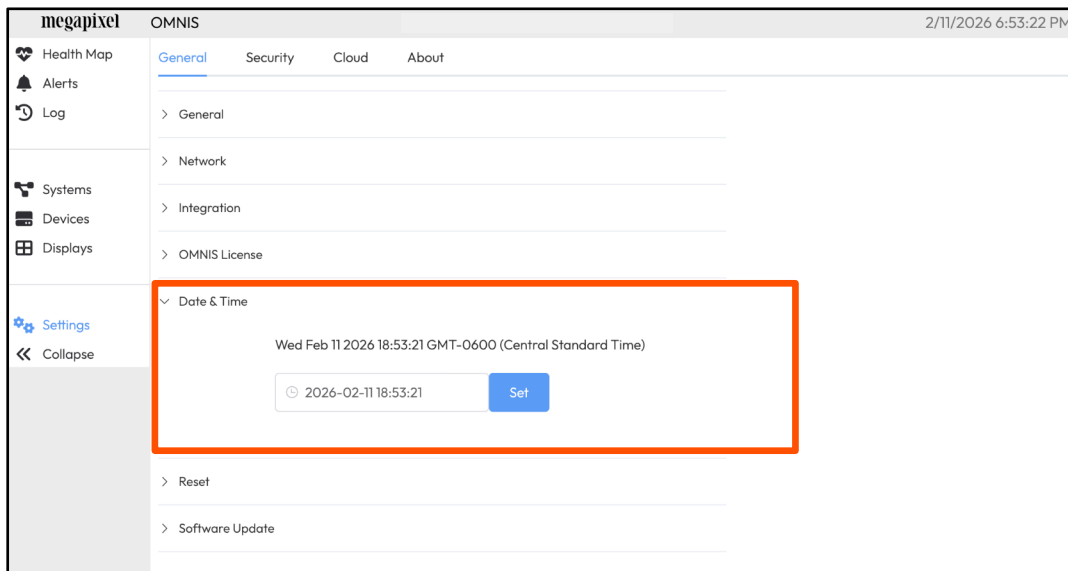

Figure 20: Set Date & Time

**NOTE:** OMNIS will automatically set the date and time using NTP after a reboot.

### 3.5.1 General - Tab (Continued)

The **Reset** accordion contains two buttons.

**Reboot OMNIS** - restart the unit with existing settings

**Reset to factory defaults** - erase existing settings and reset to factory default.

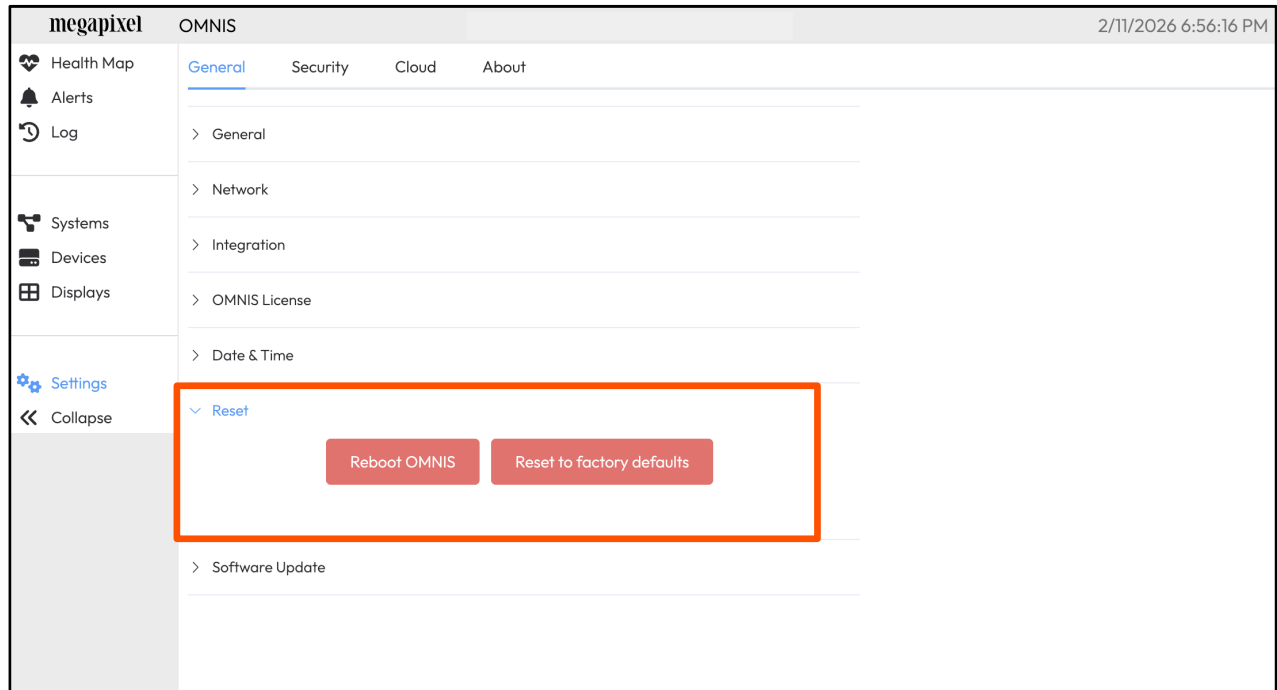

**Figure 21:** Reboot and Factory reset

### 3.5.1 General - Tab (Continued)

**Software update** accordion reports the current version and provides the **Upgrade from package** function. Press the button and navigate to the OMNIS .mvrp package to be installed.

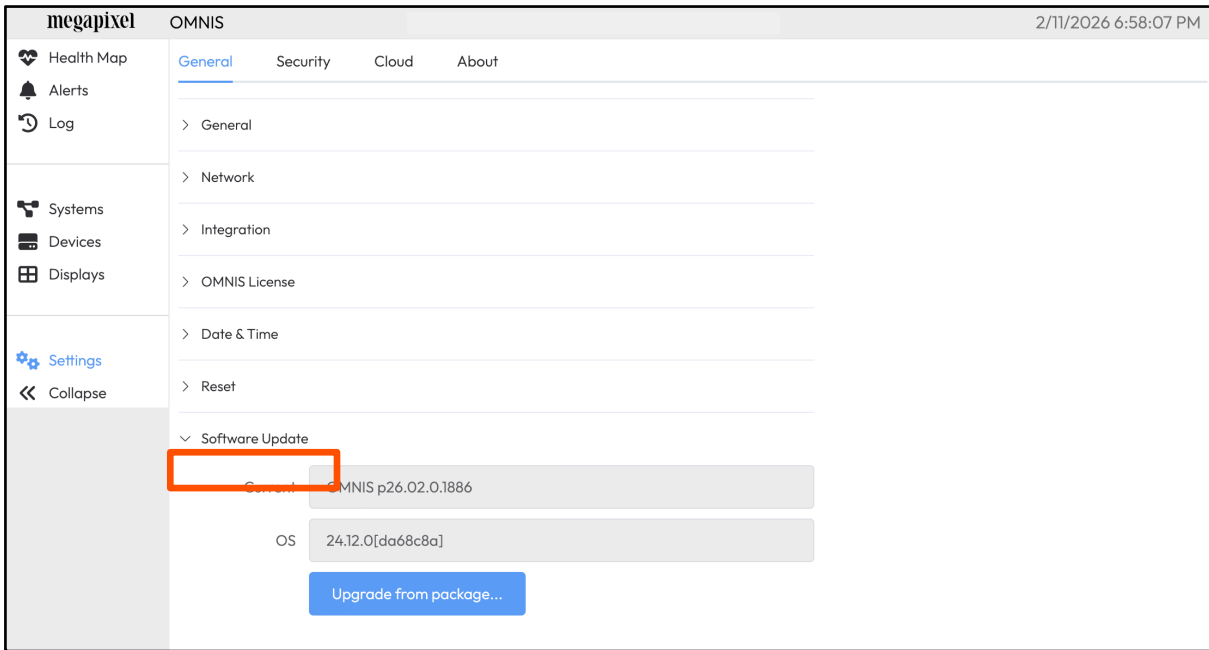
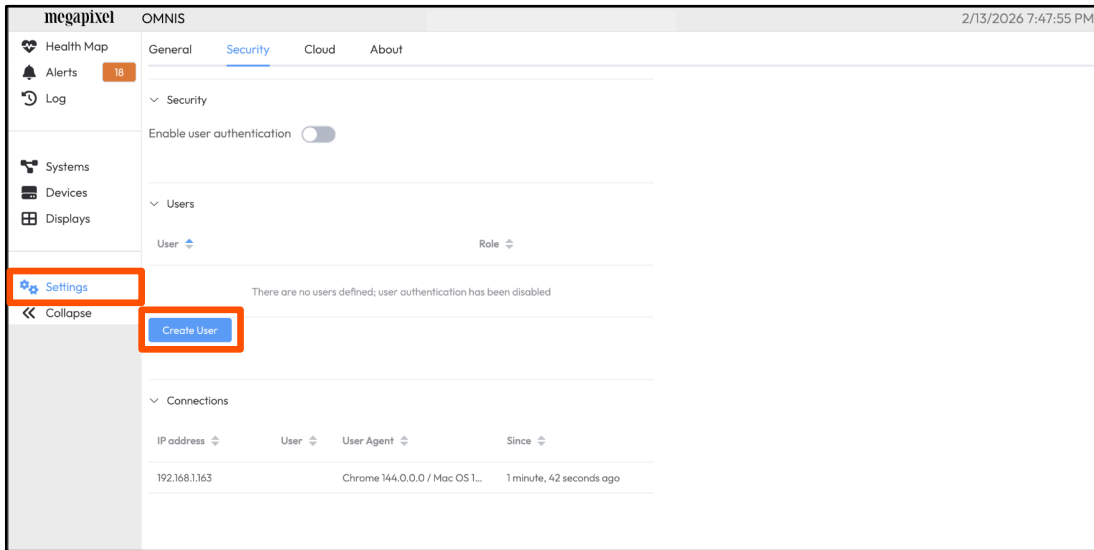

**Figure 22:** Software update

**NOTE:** Once the .mvrp package is selected, the OMNIS will warn that the system will go offline as part of the upgrade process.

### 3.5.2 Security - Tab

In the Security tab, OMNIS can be configured to require a user and password for access. Press the **Create User** button to open a form window for the user info. It is good practice to create an Admin account first. Once security is enabled, standard users will only see a list of logged in users.



**Figure 23:** Security tab

Complete the fields, then press **Add User** to create the account.

The 'Create User' dialog box contains the following fields: a required text input for 'User', a text input for 'Password', a text input for 'Confirm password', and a required dropdown menu for 'Role' with 'Select' as the current selection. At the bottom right, there are two buttons: 'Cancel' and 'Add User'.

**Figure 24:** Create user

**NOTE:** Google maintains a list of compromised passwords. If a user is created with a simple password such as 'test' or 'password' expect a Chrome warning.

### 3.5.2 Security - Tab (Continued)

Use the **Enable user authentication** toggle to turn on security. Be certain of the user and password prior to enabling security! If credentials are lost, only a factory default reset will unlock the OMNIS.

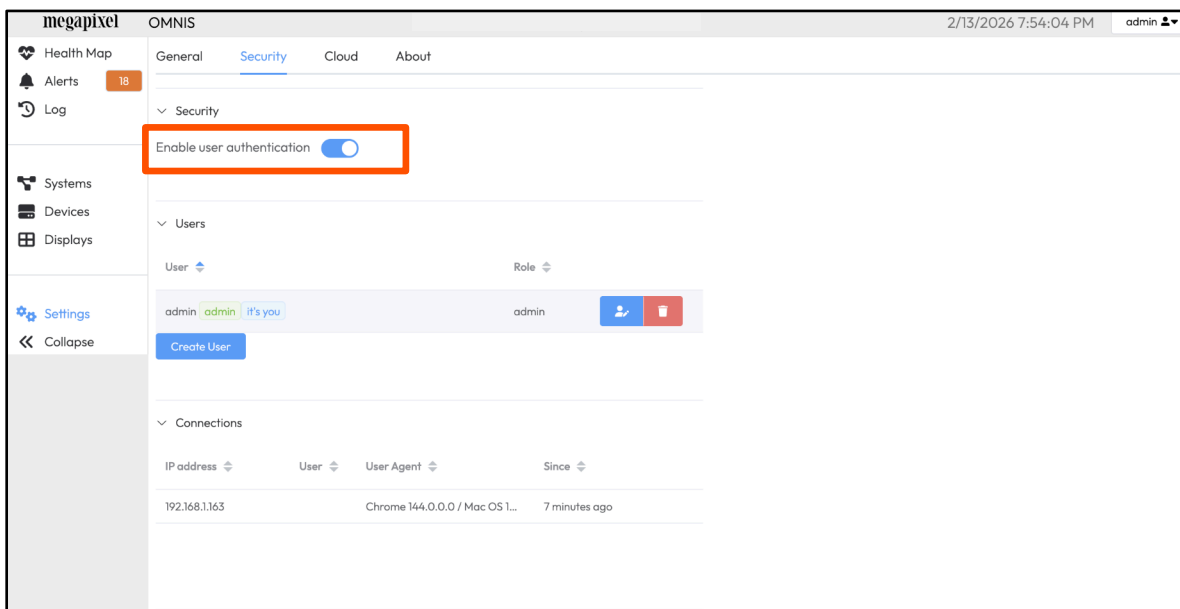

**Figure 25:** Enable user authentication

Authentication is required immediately after enabling Security!

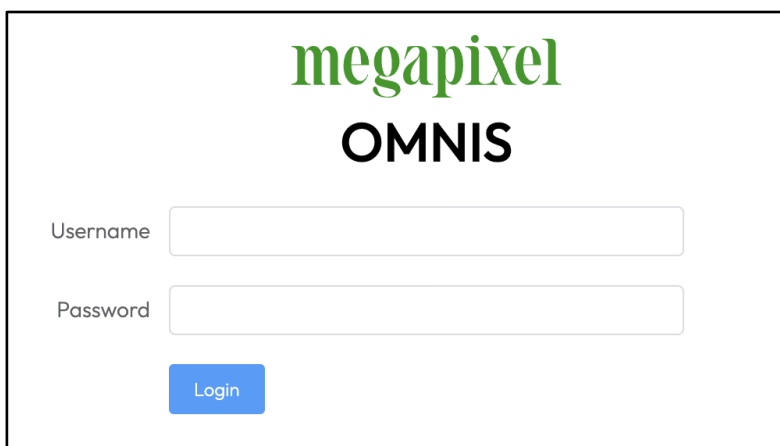

**Figure 26:** Authentication required

### 3.5.2 Security - Tab (Continued)

When logged on, the user name will appear in a button on the top right.

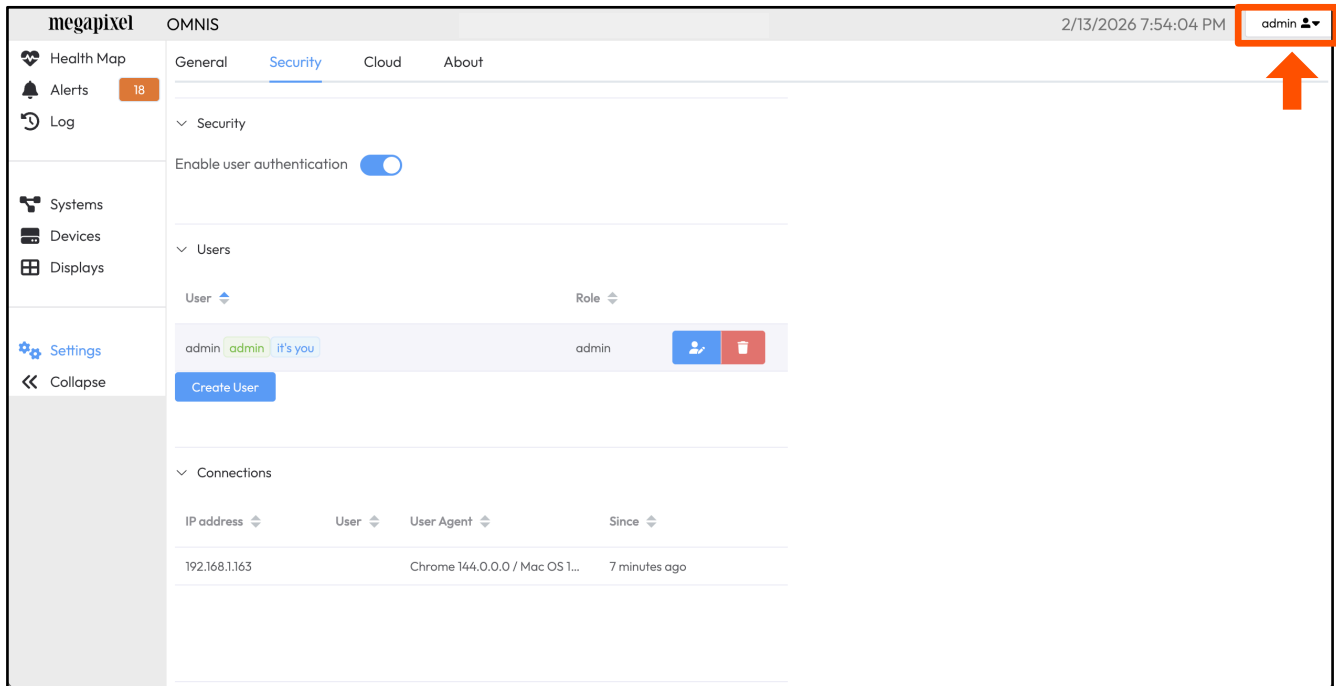

Figure 27: User list

Select the user name button at the top right (arrow above) to **Sign out** or **Change password**.

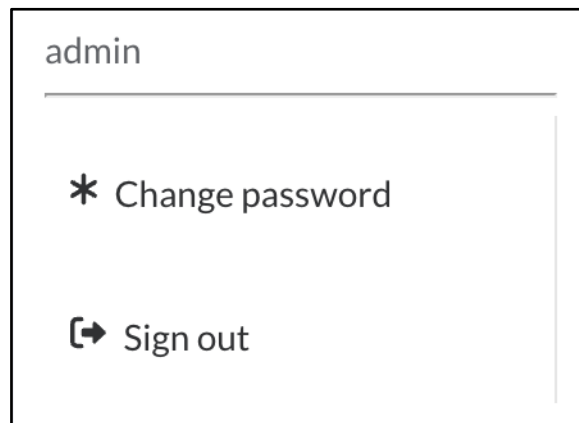

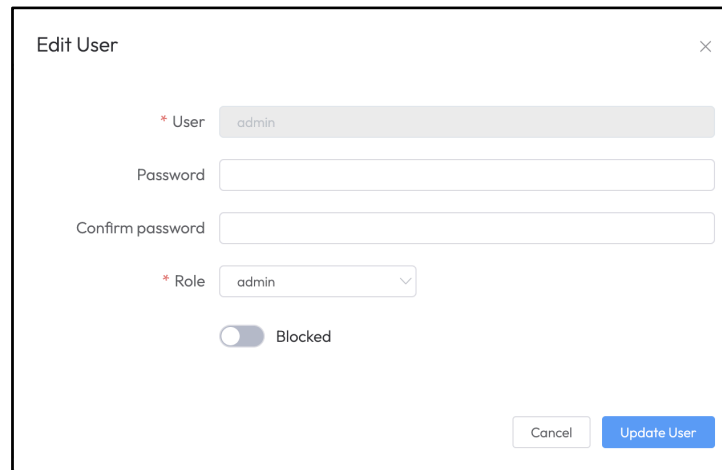

Figure 28: Sign out

### 3.5.2 Security - Tab (Continued)

Manage users with the edit and delete   buttons. Use the edit icon button to open the **Edit User** form. The password can be modified and users can be blocked. If a name change is required, it must be created as a new user.



The screenshot shows a modal window titled "Edit User" with a close button in the top right corner. The form contains the following elements:

- A text input field labeled "\* User" containing the value "admin".
- A text input field labeled "Password".
- A text input field labeled "Confirm password".
- A dropdown menu labeled "\* Role" with "admin" selected.
- A toggle switch labeled "Blocked" which is currently turned off.
- Two buttons at the bottom right: "Cancel" and "Update User".

**Figure 29:** Edit user form

If a user has been blocked, an amber notification will appear next to the user name in the user list. Blocked users are not allowed to login.

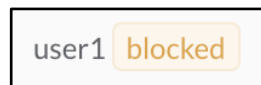

**Figure 30:** Blocked user

### 3.5.3 Cloud - Tab

Enable Cloud settings to have OMNIS accessible in a cloud environment.

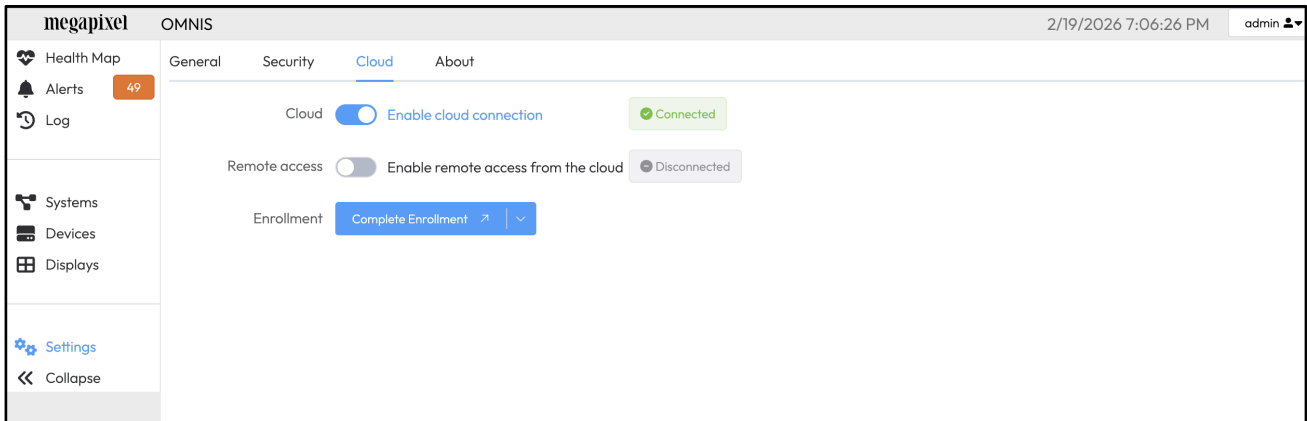

Figure 31: Settings Cloud

Press **Complete Enrollment** to be taken to the **Enroll Agent**. Create an **Organization** and a **Project** if needed. Once enrollment is complete the OMNIS will be available in the Cloud. See the Cloud documentation for more details on using this feature [help.megapixelvr.com](http://help.megapixelvr.com).

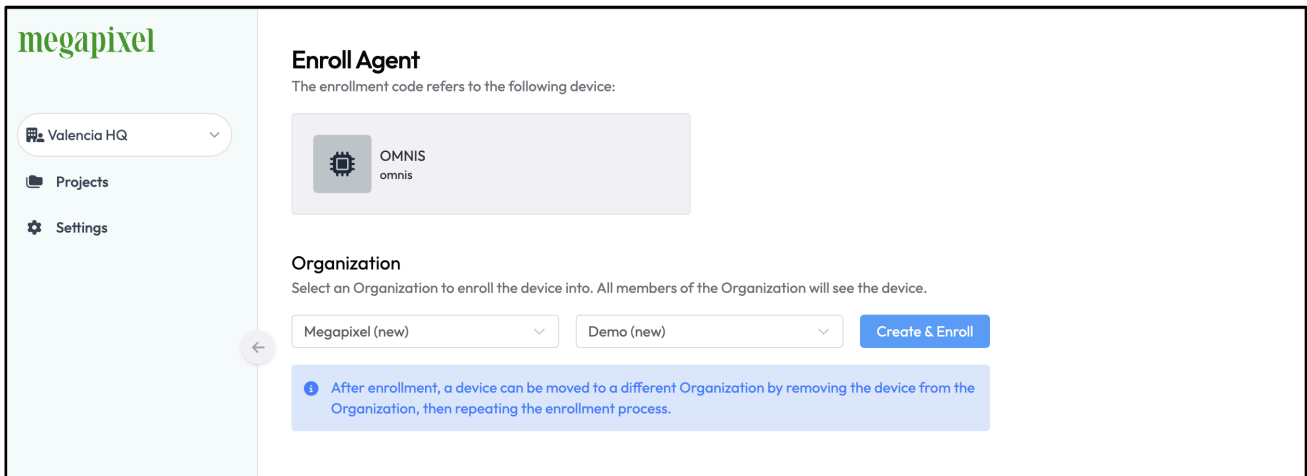

Figure 32: Enroll Agent

### 3.5.4 About - Tab

The **About** tab displays the current OMNIS version number along with some important links for contacting support. Press the **Download support archive** button to save a zip file containing OMNIS system information files that are essential to obtaining new system licenses and are helpful for troubleshooting.

The screenshot shows the 'About' tab of the OMNIS interface. The top navigation bar includes 'General', 'Security', 'Cloud', and 'About'. The main content area displays the OMNIS version (v26.03.0.1921) and copyright information (2018-2026 Megapixel). A blue button labeled 'Download support archive' is prominently displayed. Below this, a list of technologies used in the application is shown, including Boost, Element, JSZip, Koa, MobX, Net-SNMP, Node.js, PixiJS, Sequelize, TypeScript, Vue.js, Vue Router, and Vuex, each with a brief description and license type.

Figure 33: Settings About

# 4 - Monitoring

## 4.1 Overview

Once the system setup has been completed, OMNIS continuously monitors the connected system(s). OMNIS can display two different visualizations of system information; **Health** and **Temperature**. These views are of the display as viewed from the front of the display. The **Health** view shows the system connectivity and alerts (if there are any). The Temperature view shows the temperature of each panel's CPU mapped to colors, plus any related alerts.

## 4.2 Health Map

The **Health Map** is the top item in the nav bar. In this pane, OMNIS displays the panels visually as they are mapped. Panels are shown as square or rectangular icons. The processor name for each system appears in large letters across all respective panels. Panels operating with no issues are shown in blue.

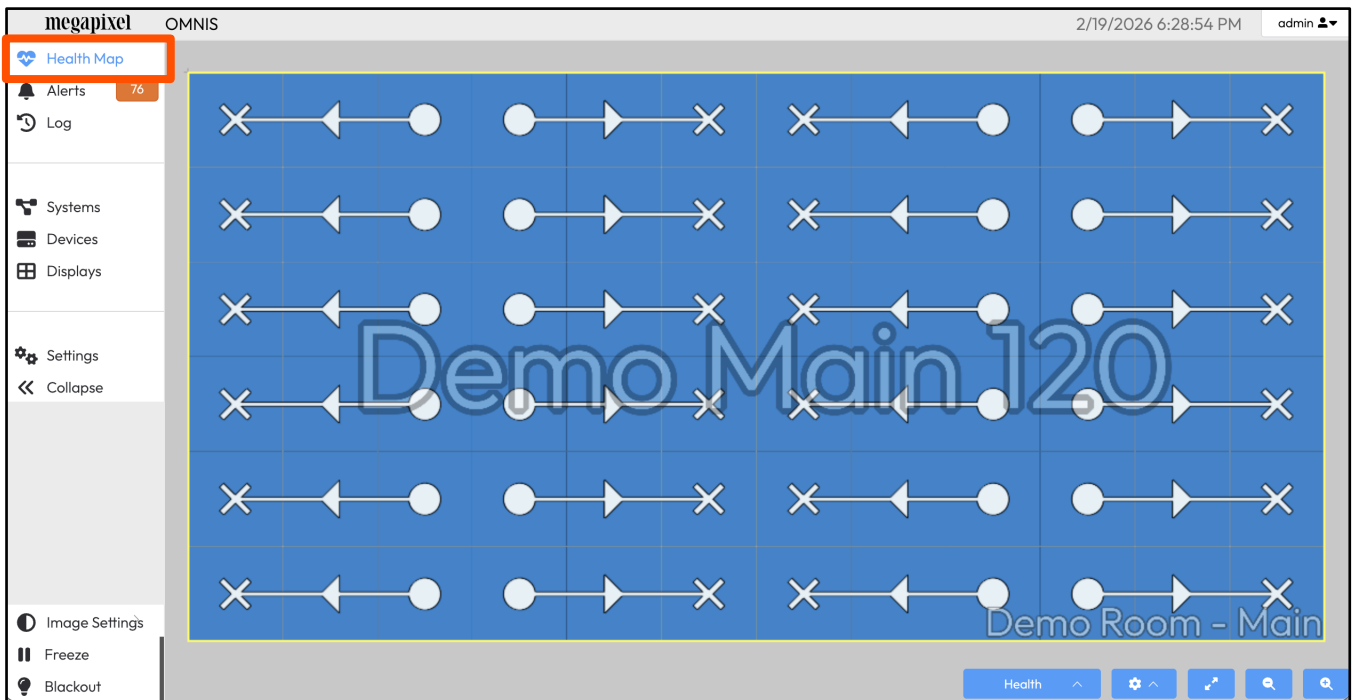

Figure 34: Health Map

## 4.2 Health Map (Continued)

Orange panels such as the ones shown below, indicate that the system has raised an alert for that panel. Select a panel icon to reveal alert details.

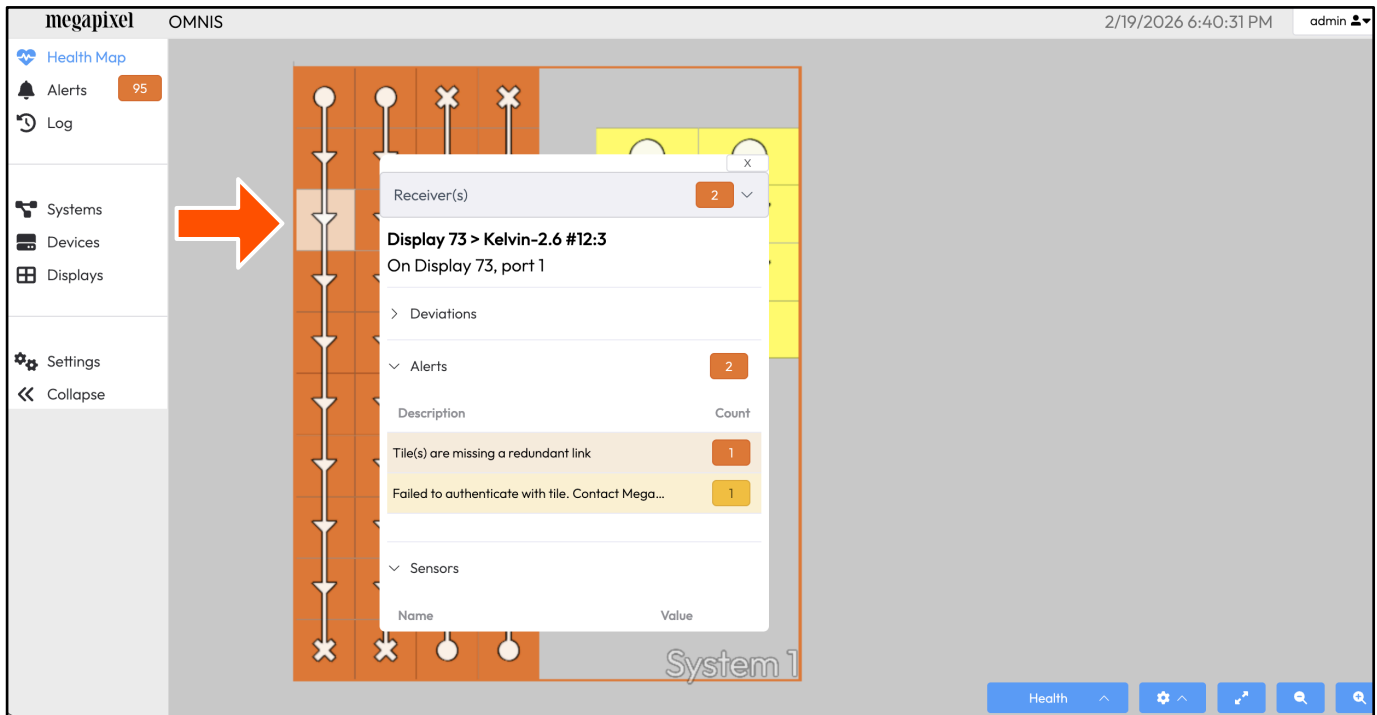

Figure 35: Alert card

Overlaid on the panel icons, are connectivity symbols. A circle represents a **Processor connection**, a triangle indicates **Passthrough**. The tips of the triangles point in the direction of the data flow. The X symbol represents the **End of a string** of panels.

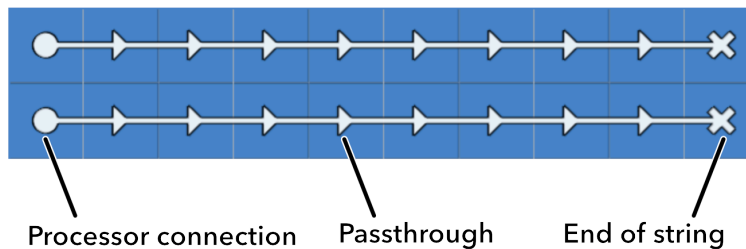

Figure 36: Connectivity symbols

## 4.2 Health Map (Continued)

Details about the display can be viewed by selecting the entire display. A pop up menu will appear with five (5) drop down options; **Receivers**, **Processors**, **Redundancy**, **Display**, and **Layout**.

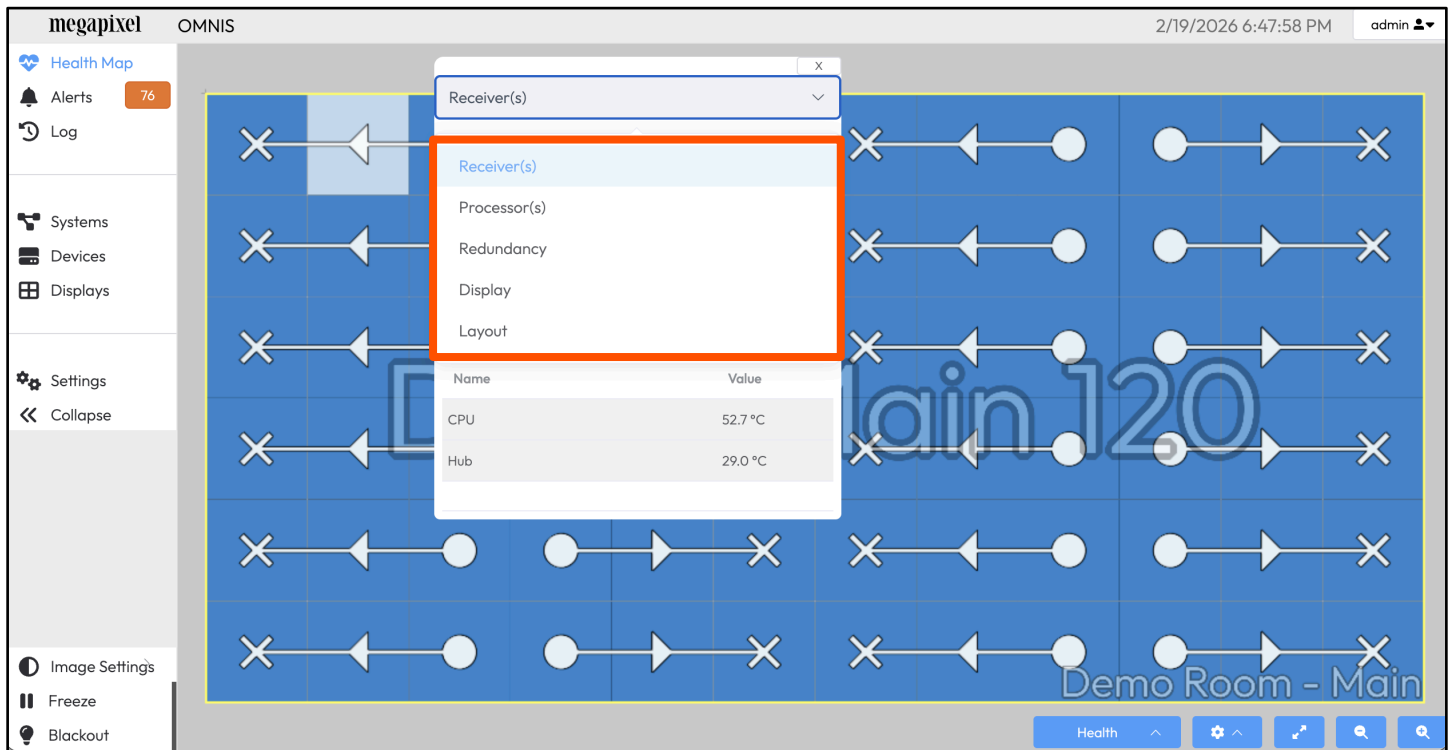

Figure 37: Display details

## 4.2.1 Temperatures Map

The **Temperatures** map shows the temperatures of panels. Temperatures are indicated in a rainbow palette that shows thermal differences in 5° increments.

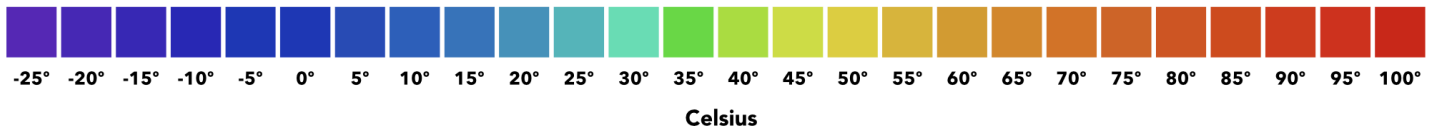

Figure 38: Color to temperature

Use this view to quickly identify any temperature anomalies in the system. The temperatures map is not just useful for recognizing panels that are excessively hot. It is good practice to warm LED panels up prior to being used at full brightness. Use the temperatures map to monitor progress and to confirm when panels are ready for use.

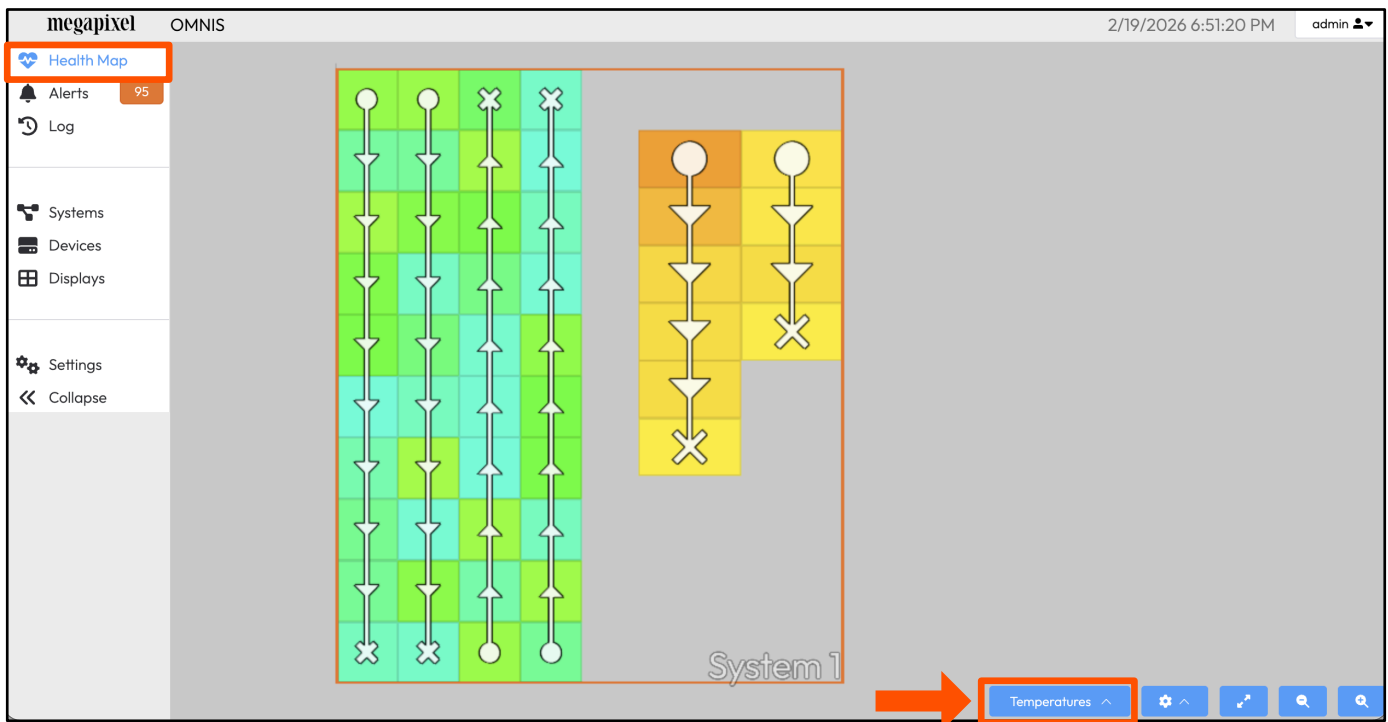

Figure 39: Temperature map

## 4.3 Alerts

The OMNIS uses color codes for alerts.

Alert Color Legend	
OK	Blue
Notice	Light Green
Warning	Yellow
Error	Orange
Critical	Red

Figure 40: OMNIS alert color code

The OMNIS UI will display all active alerts and deviations as a badge next to the alert pane select. In the alerts pane, alerts can be viewed separated into **Active Alerts** and **Deviations**.

The screenshot shows the OMNIS interface with the Alerts pane selected. The Alerts pane is divided into two sections: Active Alerts and Deviations. The Active Alerts section contains a table with columns for Count, Severity, Family, Code, and Message. The Deviations section contains a table with columns for Count, Severity, Component, Message, and Actions. An orange arrow points to the 'Alerts' badge in the top left, another orange arrow points to the 'Active Alerts' header, and a third orange arrow points to the 'Accept' button in the Deviations section.

Count	Severity	Family	Code	Message
1	Error	Processor	-	Helios Main Board does not support HDMI 2.1 Input card. Contact Megapixel
40	Error	Tile	-	Tile(s) are missing a redundant link
2	Error	Processor	-	Input is using an unrecognized format or is unstable (check upstream input format)
41	Error	Display	-	Baseline - Device is offline
2	Warning	Display	-	HELIOS engineering build. Not to be distributed. Do not use in production
40	Warning	Tile	-	Failed to authenticate with tile. Contact Megapixel
12	Warning	Tile	-	Running firmware for test only; do not use in production
1	Notice	Display	-	Developer mode is enabled; this is not a secure configuration (see Developer settings)
3	Notice	Display	-	One or more debugging network services are enabled; this is not a secure configuration (see Experimental->Debug settings)
2	Notice	Processor	-	Input's advertised EOTF is being overridden (see Input->Input Adjustments)

Count	Severity	Component	Message	Actions
1	Error	Switch	Network switch not found	Accept

Figure 41: Alerts pane

**Active** - a list of current issues in the system. As issues are resolved OMNIS will automatically clear this list.

**Deviations** - Deviations are alerts generated when OMNIS detects changes from the established baseline. For more information on baselines, see the [Baseline](#) section.

Using the **Accept** button:

- Removes the deviation from the current list.
- Clears the corresponding highlight in the alert log.
- Updates the associated system's baseline with the recorded deviation.

Examples:

- Panel replacement: When panels are replaced, each panel change triggers a deviation. Use the **Accept** button to update the system baseline with the new panels.
- Input type change: If an input type changes (e.g., DisplayPort → HDMI), OMNIS flags it as a deviation. Once accepted, OMNIS will monitor for further input changes and raise new deviations as needed.

## 4.4 Log

The Log pane displays a historical view of all alerts. After active alerts are cleared, they can still be found in the Log pane. When navigating long log records looking for specific types of alerts, it can be helpful to use the filters at the top of the page. Logs can be viewed in two (2) ways Compact and Relaxed. Use the icon button  next to the filters icon button to switch between these two view modes.

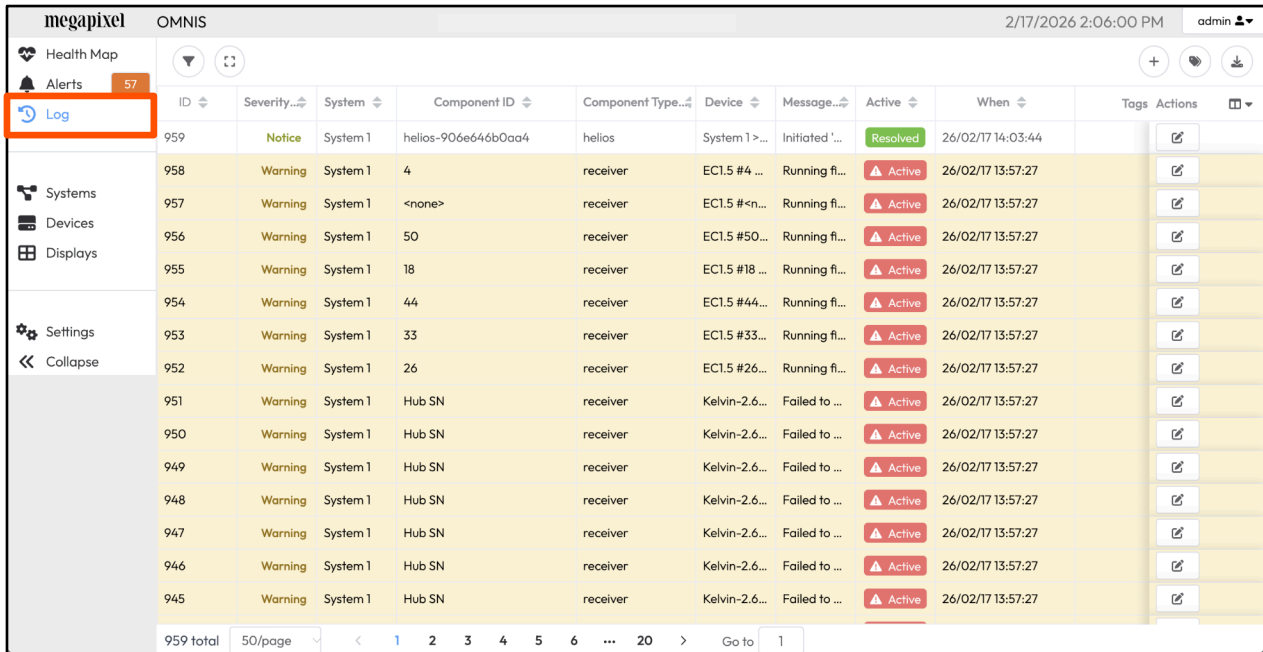

ID	Severity	System	Component ID	Component Type	Device	Message	Active	When	Tags	Actions
959	Notice	System 1	helios-906e646b0aa4	helios	System 1 >...	Initiated ...	Resolved	26/02/17 14:03:44		
958	Warning	System 1	4	receiver	EC1.5 #4 ...	Running fi...	Active	26/02/17 13:57:27		
957	Warning	System 1	<none>	receiver	EC1.5 #<n...	Running fi...	Active	26/02/17 13:57:27		
956	Warning	System 1	50	receiver	EC1.5 #50...	Running fi...	Active	26/02/17 13:57:27		
955	Warning	System 1	18	receiver	EC1.5 #18 ...	Running fi...	Active	26/02/17 13:57:27		
954	Warning	System 1	44	receiver	EC1.5 #44...	Running fi...	Active	26/02/17 13:57:27		
953	Warning	System 1	33	receiver	EC1.5 #33...	Running fi...	Active	26/02/17 13:57:27		
952	Warning	System 1	26	receiver	EC1.5 #26...	Running fi...	Active	26/02/17 13:57:27		
951	Warning	System 1	Hub SN	receiver	Kelvin-2.6...	Failed to ...	Active	26/02/17 13:57:27		
950	Warning	System 1	Hub SN	receiver	Kelvin-2.6...	Failed to ...	Active	26/02/17 13:57:27		
949	Warning	System 1	Hub SN	receiver	Kelvin-2.6...	Failed to ...	Active	26/02/17 13:57:27		
948	Warning	System 1	Hub SN	receiver	Kelvin-2.6...	Failed to ...	Active	26/02/17 13:57:27		
947	Warning	System 1	Hub SN	receiver	Kelvin-2.6...	Failed to ...	Active	26/02/17 13:57:27		
946	Warning	System 1	Hub SN	receiver	Kelvin-2.6...	Failed to ...	Active	26/02/17 13:57:27		
945	Warning	System 1	Hub SN	receiver	Kelvin-2.6...	Failed to ...	Active	26/02/17 13:57:27		

Figure 42: Log pane compact view

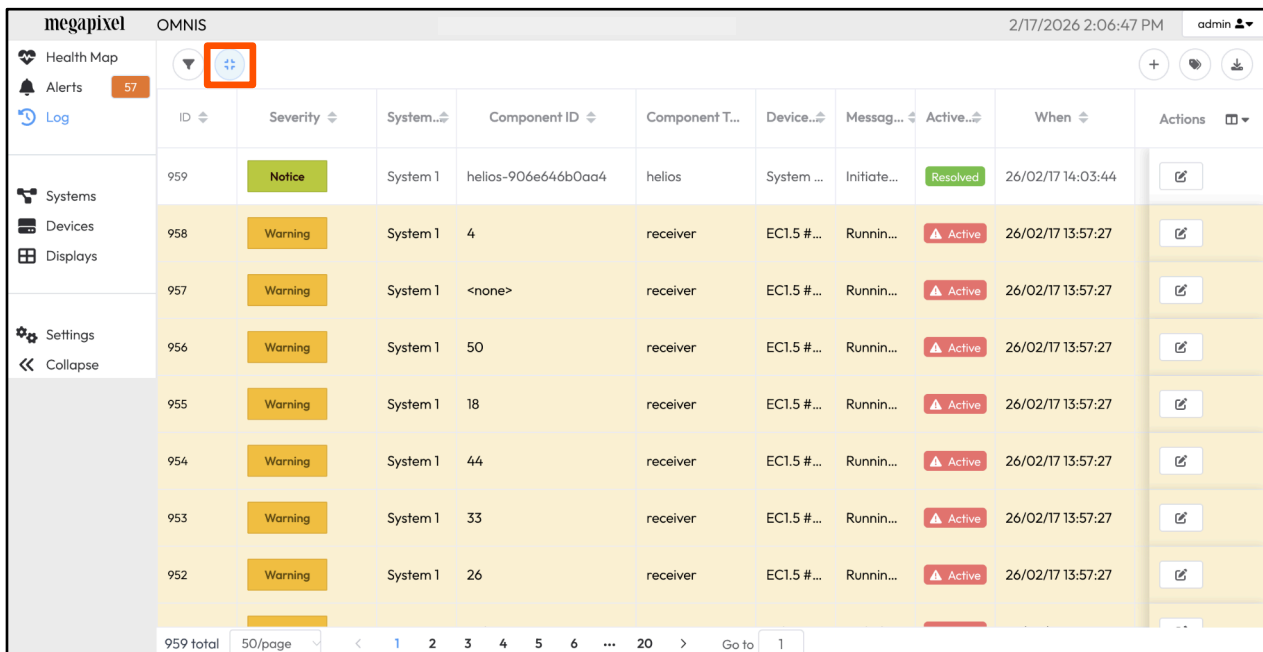

ID	Severity	System	Component ID	Component T...	Device	Message	Active	When	Actions
959	Notice	System 1	helios-906e646b0aa4	helios	System ...	Initiate...	Resolved	26/02/17 14:03:44	
958	Warning	System 1	4	receiver	EC1.5 #...	Runnin...	Active	26/02/17 13:57:27	
957	Warning	System 1	<none>	receiver	EC1.5 #...	Runnin...	Active	26/02/17 13:57:27	
956	Warning	System 1	50	receiver	EC1.5 #...	Runnin...	Active	26/02/17 13:57:27	
955	Warning	System 1	18	receiver	EC1.5 #...	Runnin...	Active	26/02/17 13:57:27	
954	Warning	System 1	44	receiver	EC1.5 #...	Runnin...	Active	26/02/17 13:57:27	
953	Warning	System 1	33	receiver	EC1.5 #...	Runnin...	Active	26/02/17 13:57:27	
952	Warning	System 1	26	receiver	EC1.5 #...	Runnin...	Active	26/02/17 13:57:27	

Figure 43: Log pane relaxed view

## 4.4 Log (Continued)

Press the pencil icon  to tag or comment on a line. Tagging can be useful for adding details about system events to help set them apart from the rest. Create tags as they are needed by selecting a word or phrase that can be consistently reused. A person's name could be used to let them easily identify which alerts they need to deal with, or simply create the 'ignore' tag for items that do not need attention.

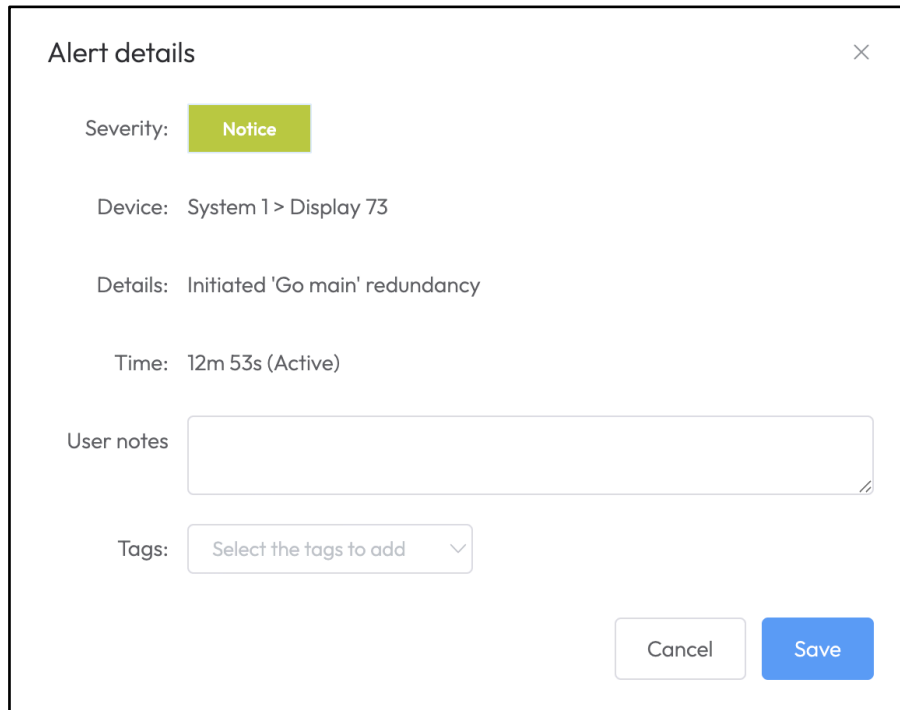

The image shows a dialog box titled "Alert details" with a close button (X) in the top right corner. The dialog contains the following information:

- Severity: Notice (highlighted in a green box)
- Device: System 1 > Display 73
- Details: Initiated 'Go main' redundancy
- Time: 12m 53s (Active)
- User notes: A large text input field with a pencil icon in the bottom right corner.
- Tags: A dropdown menu with the text "Select the tags to add" and a downward arrow.

At the bottom right of the dialog are two buttons: "Cancel" and "Save".

**Figure 44:** Notes and Tags

## 4.5 Global Controls

When connected to a HELIOS with **Monitor + Control** access, the global controls appear in the bottom left corner.

**Image Settings** - Controls for Brightness and Gamma.

**Freeze** - will continuously display a still image of the last input frame at the time pause was pressed. This feature is convenient to use when the input signal must be interrupted, and the live display can show a still image such as a logo. To use this feature, display the desired image and press the **Freeze** button. The input signal can now be interrupted and the HELIOS Processor will continue to display the still frame grab. When it comes time to resume playback, display the same image again with the connected playback device and toggle **Freeze** off.

**Blackout** - is a black generator that ensures all LEDs are completely off. This feature is ideal to use for situations when panels need to be placed on stand-by with power use at a minimum.

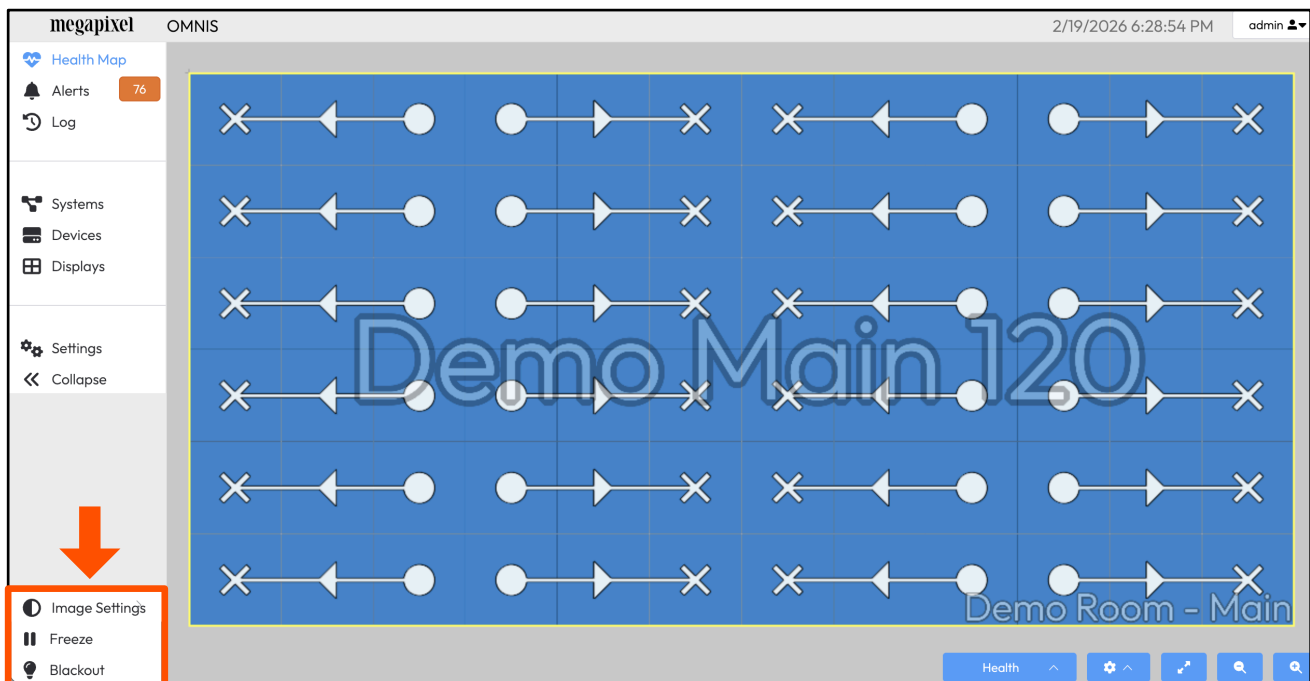

Figure 45: Global Controls

# 5 - Maintenance

## 5.1 General Maintenance

Proper maintenance of the OMNIS involves periodically checking the hardware for any parts that may have come loose or become damaged. Connectors should be checked and the unit replaced if housings have become damaged or pins are bent or deformed.

The heat sink of the OMNIS should not be allowed to accumulate large quantities of dust as the unit relies on this for cooling.

- Power off and unplug the OMNIS before starting any cleaning.
- If possible, move the OMNIS outside or to a well-ventilated area to avoid spreading dust indoors.
- Use a can of compressed air in short bursts to blow away dust and debris from the top heatsink.
- A soft brush (such as a paintbrush or anti-static brush) can help remove dust that compressed air misses.

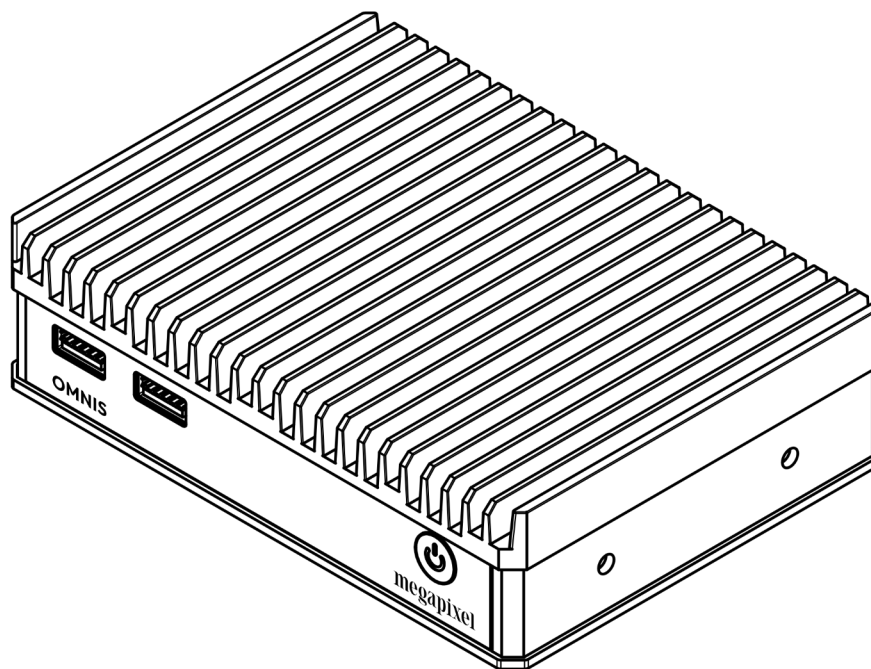

**Figure 46:** OMNIS Top heat sink.

# A - OMNIS-ISAAC Setup

## A.1 Overview

This appendix describes how to register an OMNIS module in ISAAC, link it to the OMNIS system. The procedure is intended for administrators who already have a running OMNIS system and ISAAC server on the same reachable network.

## A.2 Requirements

Before you begin, ensure the following:

- ISAAC server is installed, licensed, and accessible via web browser.
- OMNIS system is installed, licensed, and accessible via web browser.
- Network connectivity exists between ISAAC and OMNIS (IP routing and any firewall rules permit HTTPS/HTTP between them).
- You know the ISAAC server IP address that OMNIS will use to connect.
- An ISAAC account with permissions to manage Modules and Panels (typically an Admin role).

## A.3 Step-by-Step Procedure

1. Log in to ISAAC using an administrator account.
2. Open **Settings** → **Modules**.

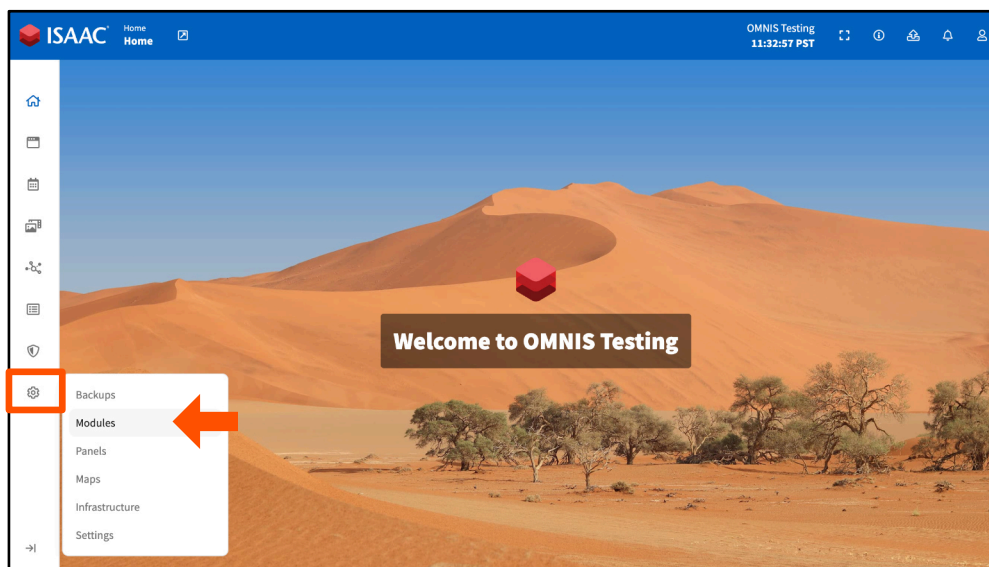

Figure 47: Settings Modules

## A.3 Step-by-Step Procedure (Continued)

3. Click **Register Module**.

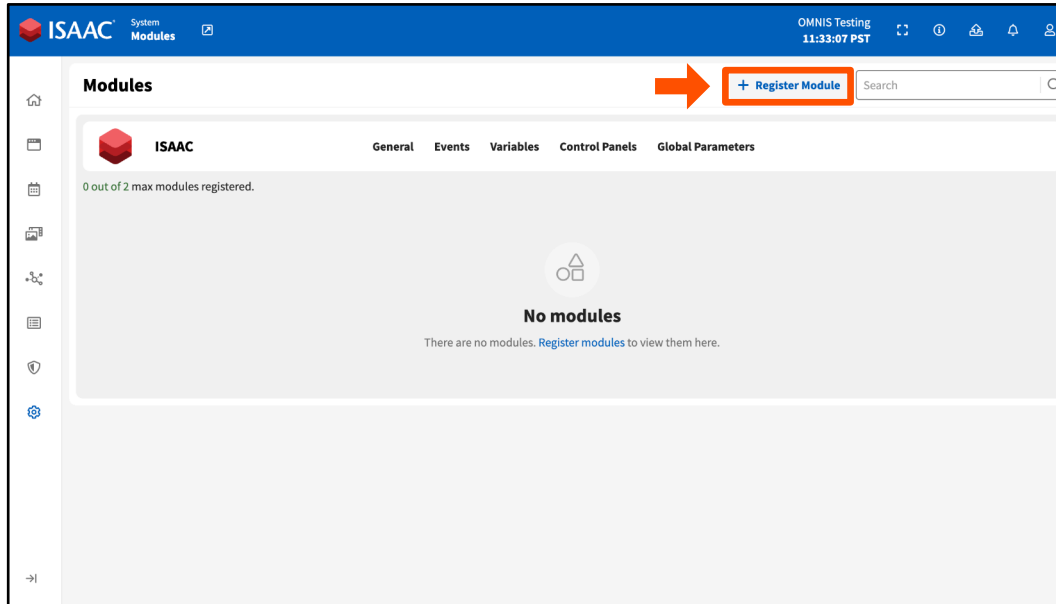

Figure 48: Register Module

4. In the registration form, enter the following values:

- Module Type: **Megapixel OMNIS**
- Module Name: **OMNIS**
- Module ID: **OMNIS**
- Hosting: **External**
- Click **Save Changes**.

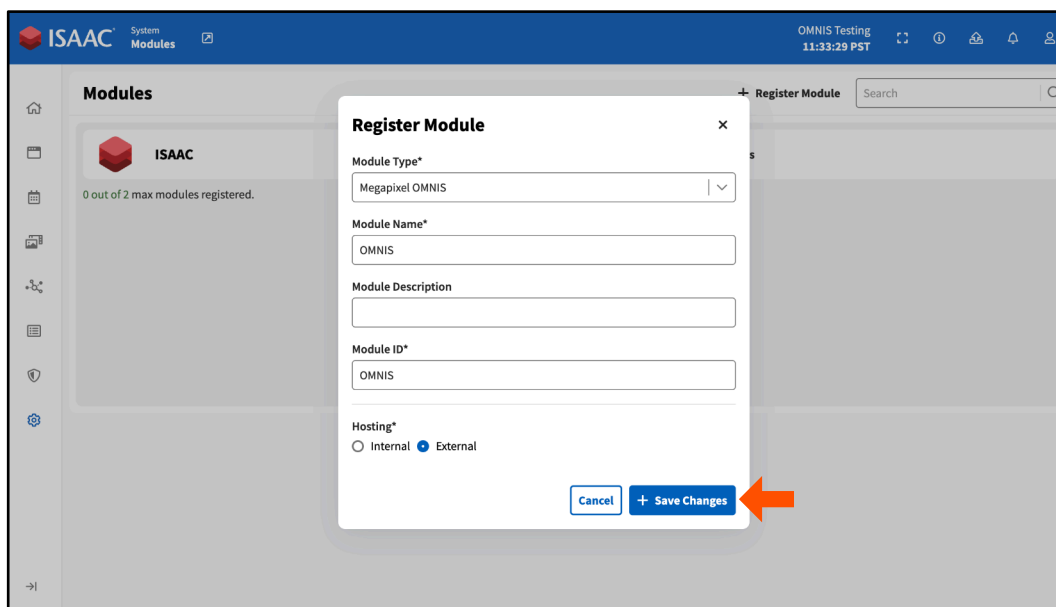
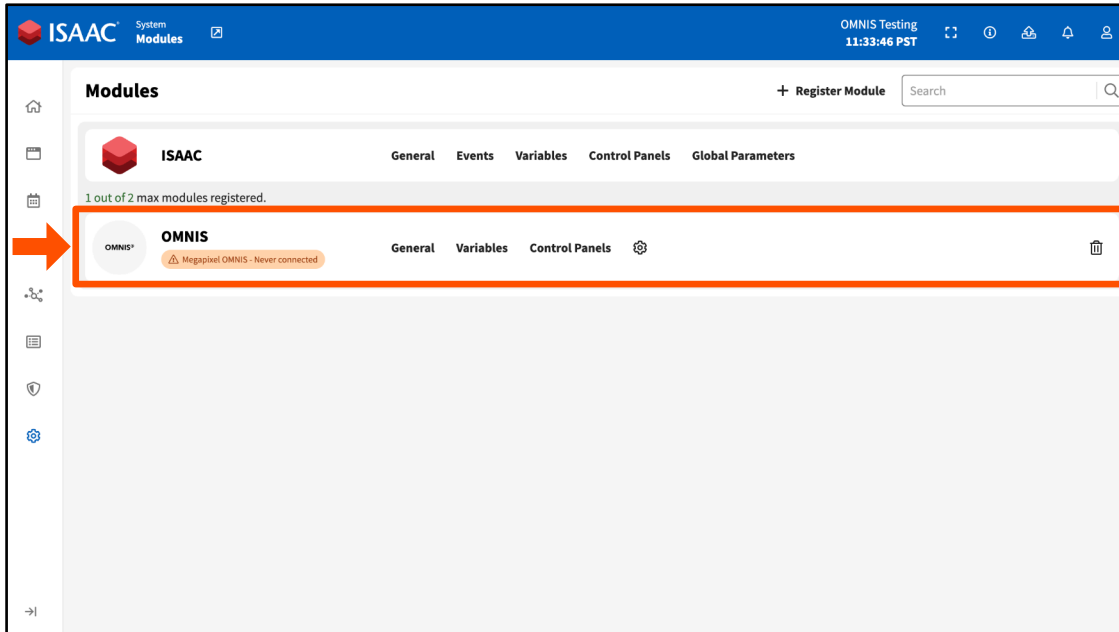

Figure 49: Register Module form

## A.3 Step-by-Step Procedure (Continued)

5. Verify that the new OMNIS module now appears in the **Modules** list.



**Figure 50:** Verify the newly added module

6. Enable ISAAC integration on OMNIS. In a separate browser tab or window, log in to OMNIS. Navigate to **Settings** → **General**, then open the Integration panel.
  - Enable ISAAC connection: **On**
  - IP address: Enter the ISAAC server IP address
  - Module ID: **OMNIS** (must match the Module ID used in ISAAC)
  - Click Apply.

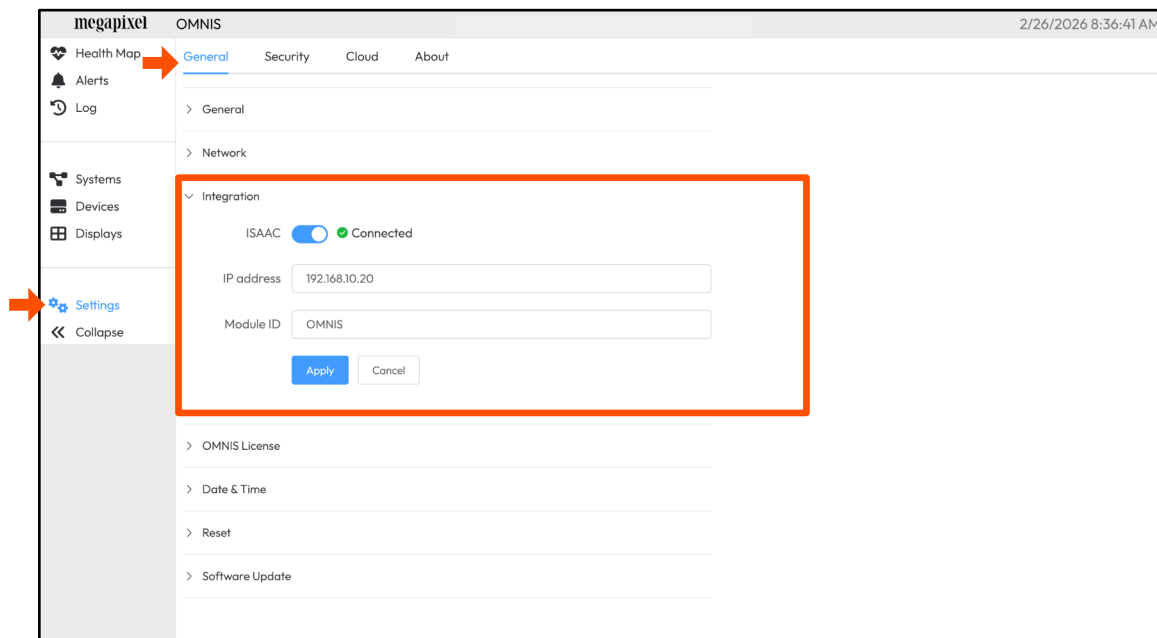

**Figure 51:** Enable ISAAC integration on OMNIS

## A.3 Step-by-Step Procedure (Continued)

7. Verify that the integration status shows **Connected**.

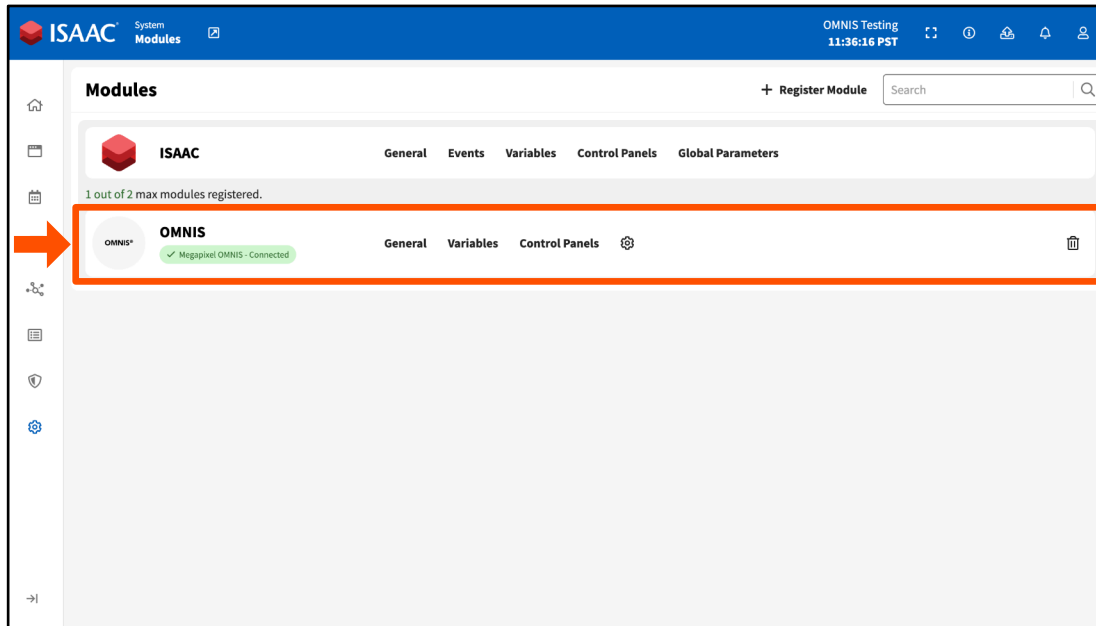

**Figure 52:** Verify the module is connected

# B - Technical Specifications

## B.1 Main Specifications Table

Dimensions	(W x H x D) 133mm (5.24") x 37mm (1.46") x 98mm (3.86")
Power Requirements	100 - 240V AC, 50Hz/60Hz, 2A (AC to DC PSU)
Weight	0.45kg   1 lb. shipping dimensions and weights on the next page
Mounting	VESA mount or tray mount
IP Rating	Indoor
Ambient Operating Temperature	0° - 60°C (32° - 140°F)
Certifications	FCC Part 15C, IEC 62368-1 (Safety), IEC 62311 (EMF), EN 300 328 (Radio/Wireless), EN 301 489-1 (EMC), EN 301 489-17 (EMC for Radio), EN 55032 (EMC, Multimedia), EN 55035 (EMC Immunity), EN 61000-3-2 (EMC, Harmonics), EN 61000-3-3 (EMC, Flicker), UKCA, RoHS, REACH
Maximum Panels to monitor	TBD
Maximum Processors to monitor	200
Cooling	Fan-less
OMNIS web app	1 x Gigabit Ethernet

## B.2 OMNIS Processor - Shipping Info.

Shipping box dimensions (W x H x D)	212mm (8.35") x 69mm (2.7") x 200mm (7.87")
OMNIS	0.45kg   1 lb.

## B.3 OMNIS Processor Dimensions

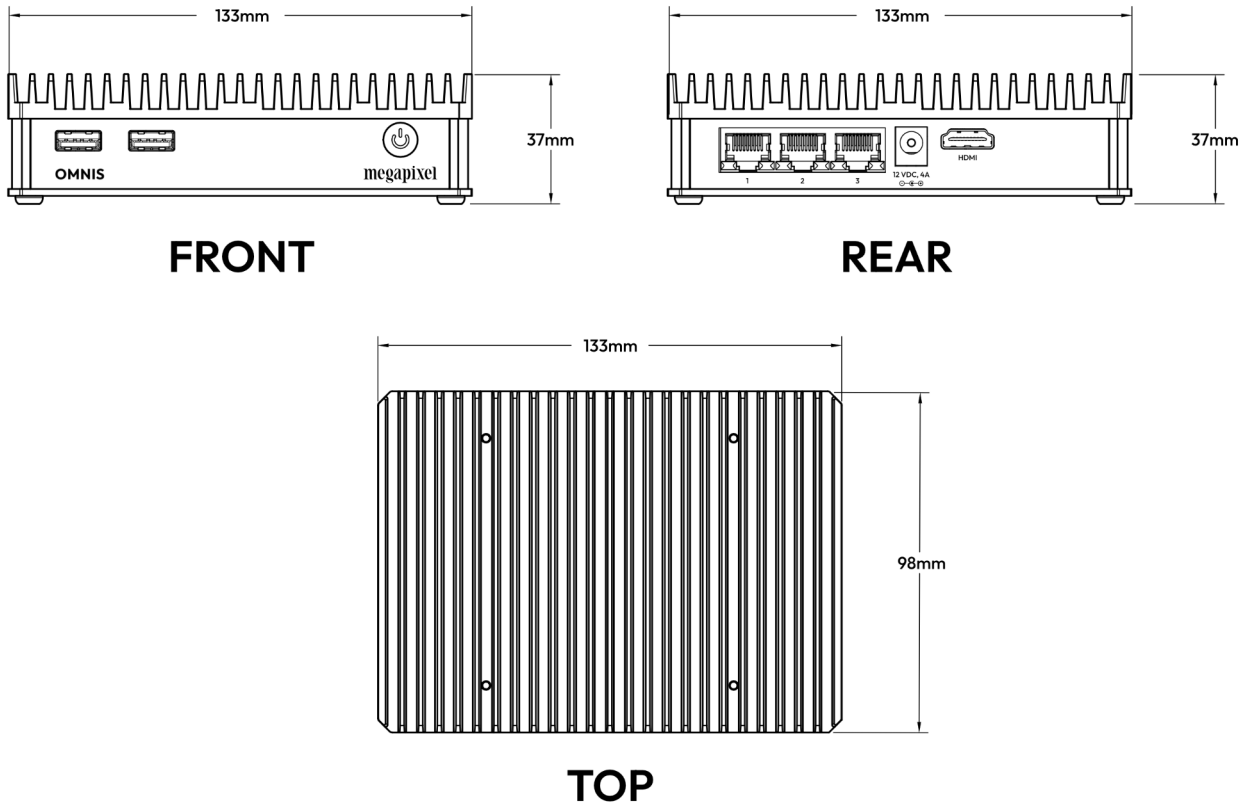

Figure 53: OMNIS dimensions

## B.4 Network Ports

The OMNIS is running a Linux build called MegaOS which is based on Alpine. The following network ports & services are used by the system:

Network Ports	Notes
22 (SSH)	Only through private key authentication for developers
80 (HTTP)	Main Web UI and Public API
443 (TCP Outbound)	General Megapixel Cloud connections
1900 (UPnP)	Service Discovery
2222 (TCP Outbound)	Megapixel Cloud back-channeled remote connections
5353 (Multicast DNS)	Service Discovery